

Operating Manual

Translation of the Original Instructions



High Power-MicroSpotMonitor-Industry

Hardware and Software Interface

PLC
PROFIBUS

PRIMES - The company

PRIMES is a manufacturer of measuring devices used for the characterization of laser beams. These devices are used for the diagnostics of high power lasers that range from CO₂ lasers to solid-state lasers or diode lasers. The wavelength range is covered from infrared to near UV. A great variety of measuring devices for the determination of the following parameters is available:

- The laser power
- The beam radius and beam length of an unfocussed beam
- The beam radius and beam length of a focussed beam
- The diffraction index M^2
- The polarization of the laser beam

Both the development and the production of the measuring the devices are effected by PRIMES. This is how we ensure an optimal quality, excellent service and a short reaction time which is the basis to meet our customers' requirements fast and reliably.



Max-Planck-Str. 2 - 64319 Pfungstadt - Germany - info@primes.de - www.primes.de

Contents

PRIMES - THE COMPANY		3
1	BASIC SAFETY INSTRUCTIONS	7
2	SYMBOL EXPLANATIONS	8
3	CONDITIONS AT THE INSTALLATION SITE	9
4	SYSTEM DESCRIPTION	10
4.1	Measuring system.....	11
4.1.1	Focus measurement.....	11
4.1.2	Power measurement.....	12
4.1.3	Power calibration.....	12
4.2	Operation.....	13
4.3	Connections.....	13
4.4	Protective functions.....	14
4.5	Display.....	15
5	OVERVIEW CONNECTOR PANEL	17
6	TRANSPORT AND INSTALLATION	18
6.1	Mounting Position and Attachment.....	18
6.2	Alignment to the laser beam axis.....	23
7	MECHANICAL CONNECTIONS	24
7.1	Cooling Circuit System.....	24
7.1.1	Requirements.....	24
7.1.2	Connecting.....	24
7.2	Compressed air.....	24
7.3	Fiber connection.....	26
7.3.1	Changing the fiber adapter.....	26
8	ELECTRICAL CONNECTIONS	27
8.1	Power supply.....	27
8.2	Trigger In/Out.....	27
8.3	Photodiode Out.....	27
8.4	PRIMES Bus.....	27
8.5	PLC IN/OUT.....	28
8.5.1	Output line, plug OUT/LO (Low-Word).....	28
8.5.2	Output lines, plug OUT/Hi (High-Word).....	29
8.5.3	Input lines, plug IN/Lo (Low-Word).....	30
8.5.4	Input lines, plug IN/Hi (High-Word).....	31
8.6	Ethernet connection (RJ-45).....	32
8.7	Confirmation Button.....	32
8.8	Safety Circuit (Safety Interlock Process/Fiber).....	33
9	SOFTWARE	35
9.1	System requirements.....	35
9.2	Installing the software.....	35
9.3	Starting the Software.....	35
9.4	Entering the device address.....	36
9.5	User level **OPTION**	37
9.6	Graphical user interface.....	38
9.7	Overview of the program functions.....	41
9.8	Basic settings for a fast CW measurement.....	44
9.9	Setting possibilities in the software interface.....	46
9.9.1	Operating mode.....	47
9.9.2	Pre-settings.....	48

9.9.3	System test	50
9.9.4	Professional mode	51
9.9.5	Interlock	53
9.9.6	Documentation	54
9.9.7	Evaluation	55
9.9.8	System monitoring	56
9.9.9	Optical load	57
9.9.10	Dialogue window <i>Option</i> (Standard menu <i>Measurement</i>)	58
9.9.11	Dialogue window <i>Sensor parameters</i> (Standard menu <i>Measurement</i>)	60
9.9.12	Dialogue window <i>Measuring Environment</i>	61
9.9.13	Dialogue window <i>Measurement settings</i>	62
9.9.14	Dialogue window <i>Caustic settings</i>	63
9.10	Presentation and documentation of the measuring results	64
9.10.1	False colors	65
9.10.2	False colors (filtered)	66
9.10.3	Isometry 3D	66
9.10.4	Review 86 % -respectively- 2nd Moment	67
9.10.5	Caustic display (2D-display)	69
9.10.6	Symmetry check	71
9.10.7	Fixed contour lines	72
9.10.8	Variable contour lines	73
9.10.9	Graphical review	73
9.10.10	Color tables	74
9.10.11	Position	74
9.11	File administration	75
9.11.1	New	75
9.11.2	Open	75
9.11.3	Save	75
9.11.4	Save as	75
9.11.5	Export	75
9.11.6	Load measurement preferences	75
9.11.7	Save measurement preferences	76
9.11.8	Protocol	76
9.11.9	Print	76
9.11.10	Print preview	76
9.11.11	Recently opened file	76
9.11.12	Exit	76
9.12	Edit	77
9.12.1	Copy	77
9.12.2	Clear plane	77
9.12.3	Clear all planes	77
9.12.4	Change user level **OPTION**	77
10	MEASURE	78
10.1	Manual operation (script control)	78
10.1.1	Script "Focus Caustic Fiber" **OPTION**	80
10.1.2	Script "Focus Caustic Beam" **OPTION**	81
10.1.3	Script "Focus Shift Fiber" **OPTION**	82
10.1.4	Script "Focus Shift Beam" **OPTION**	83
10.1.5	Script "Characteristic Curve Fiber" **OPTION**	85
10.1.6	"Script "Self-test Protective Window"	86
10.1.7	Script "Time Constant Focus Shift Cool Down" **OPTION**	89
10.1.8	Script "Time Constant Focus Shift Warm Up" **OPTION**	91
10.1.9	"Self-Test Power Calibration" **OPTION**	93
10.1.10	Script "Qualification of all Protective Windows" **OPTION**	94
10.2	Automatic operating mode	95

10.2.1	Global settings	96
10.2.2	Fiber Test **OPTION**	98
10.2.3	Extended Measuring **OPTION**	98
10.2.4	Fast Measuring **OPTION**	99
10.2.5	Long Term Measuring **OPTION**	99
10.2.6	Power Measuring Process **OPTION**	100
10.2.7	Power Measuring Fibre **OPTION**	100
10.2.8	Electrically Calibration Test **OPTION**	101
10.3	Example for a First Measurement (Professional Mode)	102
10.3.1	Plan of procedure for the first measurement.....	102
10.3.2	Plan of procedure for the determination of caustic limits	103
10.3.3	Plan of procedure for the first caustic measurement	104
11	SYSTEM COMMUNICATION	105
11.1	Operation modes.....	106
11.1.1	Read	106
11.1.2	Write	107
11.1.3	Read status.....	108
11.2	Functions of the input or output lines	109
11.3	Register index	112
11.4	Register description (reading access).....	114
11.4.1	Status register 1 (Status1)	114
11.4.2	Status register 2 (Status2)	115
11.4.3	Power Pre-Selection (PwrPreSel_Reg)	116
11.4.4	Warning Flag Register Temperature, Media, Optics (WarnTFO_Reg).....	117
11.4.5	Warning Flag Register LaserDiagnosticsSoftware (WarnLDS_Reg).....	118
11.4.6	Error Flag Register Temperatures, Media, Optics (ErrTFO_Reg).....	119
11.4.7	Error Flag Register Mechanics, Optics, Electronics (ErrMOE_Reg).....	120
11.4.8	Error Flag Register LaserDiagnosticsoftware (ErrLDS_Reg)	121
11.4.9	Result Register Protective Window Test (ResProtectGlass)	122
11.4.10	Value register.....	123
11.4.11	Activity register command 1 (Cmd1_Run)	125
11.4.12	Active Register Command 2 (Cmd2_Run).....	125
11.4.13	Chronological sequence of the register content when a command is initiated	126
11.5	Register Description (reading and writing access).....	127
11.5.1	Command 1 (Cmd1)	127
11.5.2	Command 2 (Cmd2)	127
11.5.3	Selection Register (Select)	128
11.5.4	Test Register (Test).....	128
12	MAINTENANCE	129
12.1	Renew Protective Windows.....	129
13	STORAGE/TRANSPORT	130
14	DIMENSIONS HOUSING	131
15	CENTER OF MASS	135
16	TECHNICAL DATA	136
17	ACCESSORIES	136
18	MEASURES FOR THE PRODUCT DISPOSAL	136

1 Basic safety instructions

Intended use

The HighPower-MicroSpotMonitor-Industrie (HP-MSM-I) is exclusively intended for measurements carried out in or near the optical path of high power lasers. Other forms of usage are improper. To ensure a safe operation, the device must only be operated according to the terms stipulated by the manufacturer.

Improper usage of the device is strictly prohibited and could lead to health endangering or even deathly injuries. When operating the device it must be ensured that there are no potential hazards to human health.

The device themselves do not emit any laser radiation. During the measurement, however, the laser beam is guided through the device which may cause scattered radiation. That is why the applying safety regulations are to be observed and necessary protective measures need to be taken.

Observing applicable safety regulations

Please observe national and international regulations and norms according to ISO / CEN as well as the specifications and instruction guidelines stipulated by the Employer's Liability Insurance Association, such as IEC – 60825-1 and the accident prevention regulation for laser beams BGV B2 (this is only valid in Germany and some other EU-countries).

Taking necessary safety measures

If there are people present within the danger zone of visible or invisible laser radiation, for example near laser systems that are only partly covered, open beam guidance systems or laser processing areas, the following safety measures need to be taken:

- Please wear safety goggles adapted to the laser wave length that is in use
- Please protect yourself from direct laser radiation, scattered radiation as well as from beams generated from laser radiation (for example by using appropriate shielding walls or by weakening the radiation to a harmless level).
- Please use beam guidance – or beam absorber elements which do not emit any hazardous particles as soon as they get in contact with laser radiation and which resist the beam sufficiently.
- Please install safety switches and / or emergency safety mechanisms which enable an immediate closure of the laser shutter.
- Please ensure a stable mounting of the measuring device in order to prevent a relative motion of the device to the beam axis. This reduces the risk of scattered radiation and is also necessary to ensure an optimal performance for the measurement.

Employing qualified personnel

All users of the HP-MSM-I must have been introduced to the handling of the measuring device and need to have basic knowledge about the work with high power lasers, beam guidance systems as well as focussing units.

Modifications

The device must not be modified, neither constructional nor safety-related, without our explicit permission. Modifications of any kind will result in the exclusion of our liability for resulting damages.

Liability disclaimer

The manufacturer and the distributor of the measuring devices do not claim liability for damages or injuries of any kind resulting from an improper use or handling of the devices or the associated software. Neither the manufacturer nor the distributor can be held liable by the buyer or the user for damages to people or material or financial losses due to a direct or indirect use of the measuring devices.

2 Symbol explanations

The following symbols and signal words indicate possible residual risks:



DANGER

means that death or serious physical injuries **will** occur if necessary safety precautions are not taken.



WARNING

means that death or serious physical injuries **can** occur if necessary safety precautions are not taken.



CAUTION

means that a slight physical injury **can** occur if necessary safety precautions are not taken.

NOTICE

means that property damages **can** occur if necessary safety precautions are not taken.

- ▶ Call for action

The devices themselves bear the following symbols to indicate possible dangers:



Warning of hand injuries



Warning of a hot surface

Further symbols that are not security relevant:



Here you can find useful information and helpful tips.



With the CE marking the manufacturer guarantees that his product is in conformity with the EC guidelines



Electrical or electronic device which was put into circulation in the EU after 13th August 2005. According to EC Directive 2002/96/EC regarding the collection and recycling of electrical or electronic equipment (WEEE) it has to be disposed separately.

3 Conditions at the installation site

The HP-MSM-I must not be operated in a condensing atmosphere. The ambient temperature must be above freezing.

The temperature of the cooling water must not be below the ambient temperature. Moreover, the humidity has to be considered in order to prevent condensates on the in- and outside of the device.

4 System description

The HighPower-MicroSpotMonitor-Industry (HP-MSM-I) consists of components of the PRIMES measuring devices HighPowerMSM and EC-PowerMonitor as well as a PLC Interface. These components are combined in a robust and dust-proof aluminium housing.

With the HP-MSM-I the laser beam parameters power, beam position and beam dimensions as well as the beam distribution in the focus can be checked cyclically. Via the PLC-connection the measuring procedure can be automated.

Beam geometry and beam distribution are determined by means of a camera based diagnostic system, the power is measured according to the calorimetric principle by means of the cooling circuit.

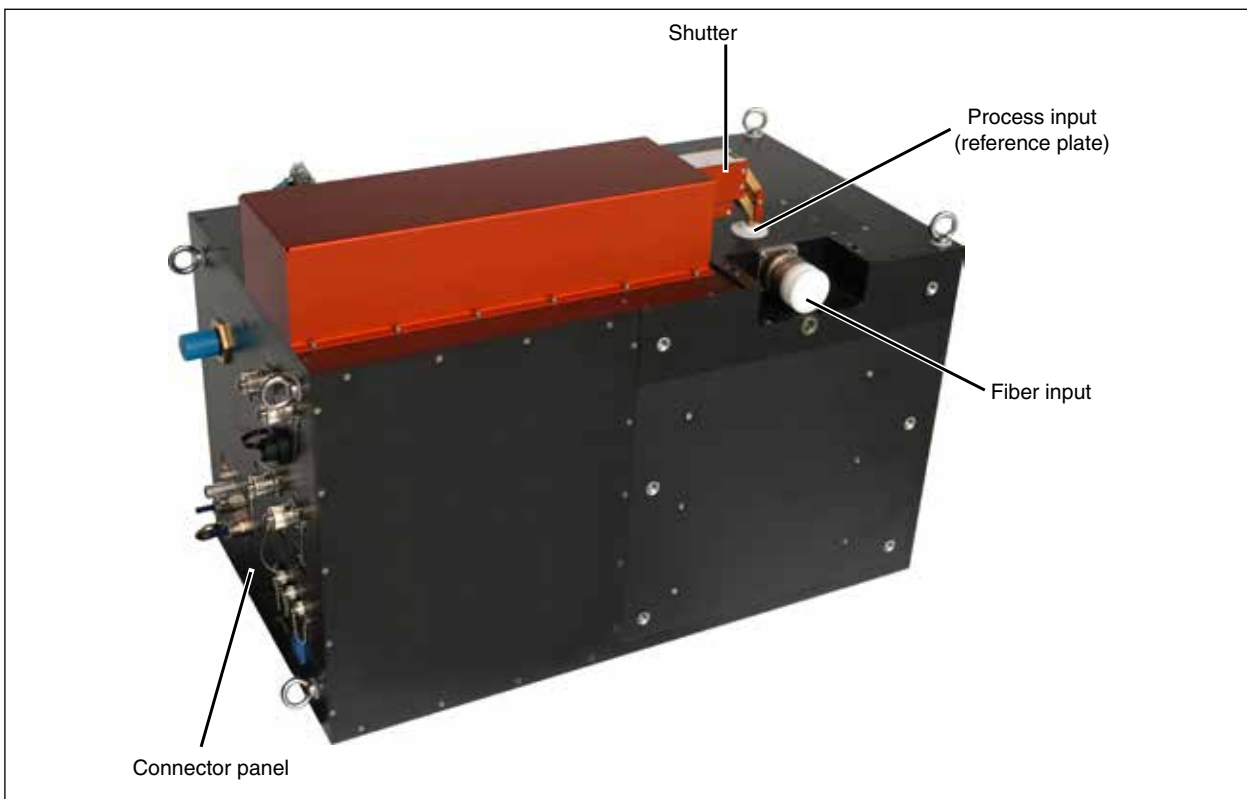

Fig.4.1: HP-MSM-I, version November 2010

The HP-MSM-I has two laser beam entrances:

- a process input for the focused laser beam
- a fiber input for the laser beam emanating from the transport fiber (reference beam).

The laser beam can either be guided through the aperture in the reference plate or via a fiber with fiber plug D. By means of a beam switch (please see Fig.4.5 on page 14) the beams of these inputs can be guided alternately to the CCD-sensor of the measurement system.

A pneumatic shutter ensures a dust-proof closure of the aperture in the reference plate after a measurement cycle.

4.1 Measuring system

In the stable aluminium housing of the HP-MSM-I the measurement components for

- the focus measurement
- the power measurement
- the power calibration

are combined.

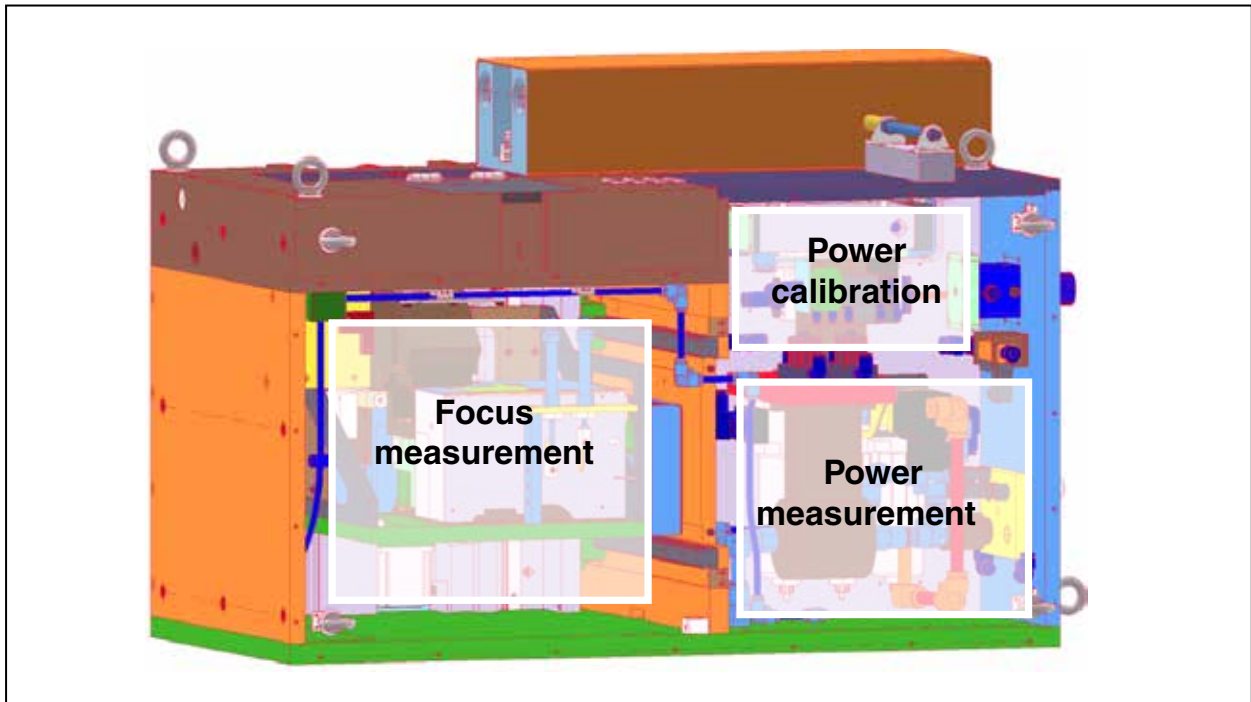

Fig.4.2: Measurement components of the HP-MSM-I

4.1.1 Focus measurement

The measuring objective for the focus measurement has a 5-fold magnification and is multiply corrected diffraction limitedly.

A beam splitter decouples 0.6 % of the irradiated power density as a measurement beam and guides it into the optics module. 99.4 % of the beam power is absorbed in the power absorber.

By means of a field lens the measurement range of the beam profile measurement can be amplified by a factor of 3. By means of a beam path extension the resolution can be increased by a factor of about 1.5 which enables the measurement of foci up to a diameter range of up to 15 μm . For the analysis of the beam propagation parameters, the optical system can be shifted by -60 up to +40 mm in beam direction.

When it comes to the fiber measurement, the measurement range is -90 to +10 mm around the nominal fiber end position.

The beam distribution decoupled in the measuring objective is weakened by up to 300 dB in the optical system and is then guided to the CCD sensor with 2.1 mega pixels.

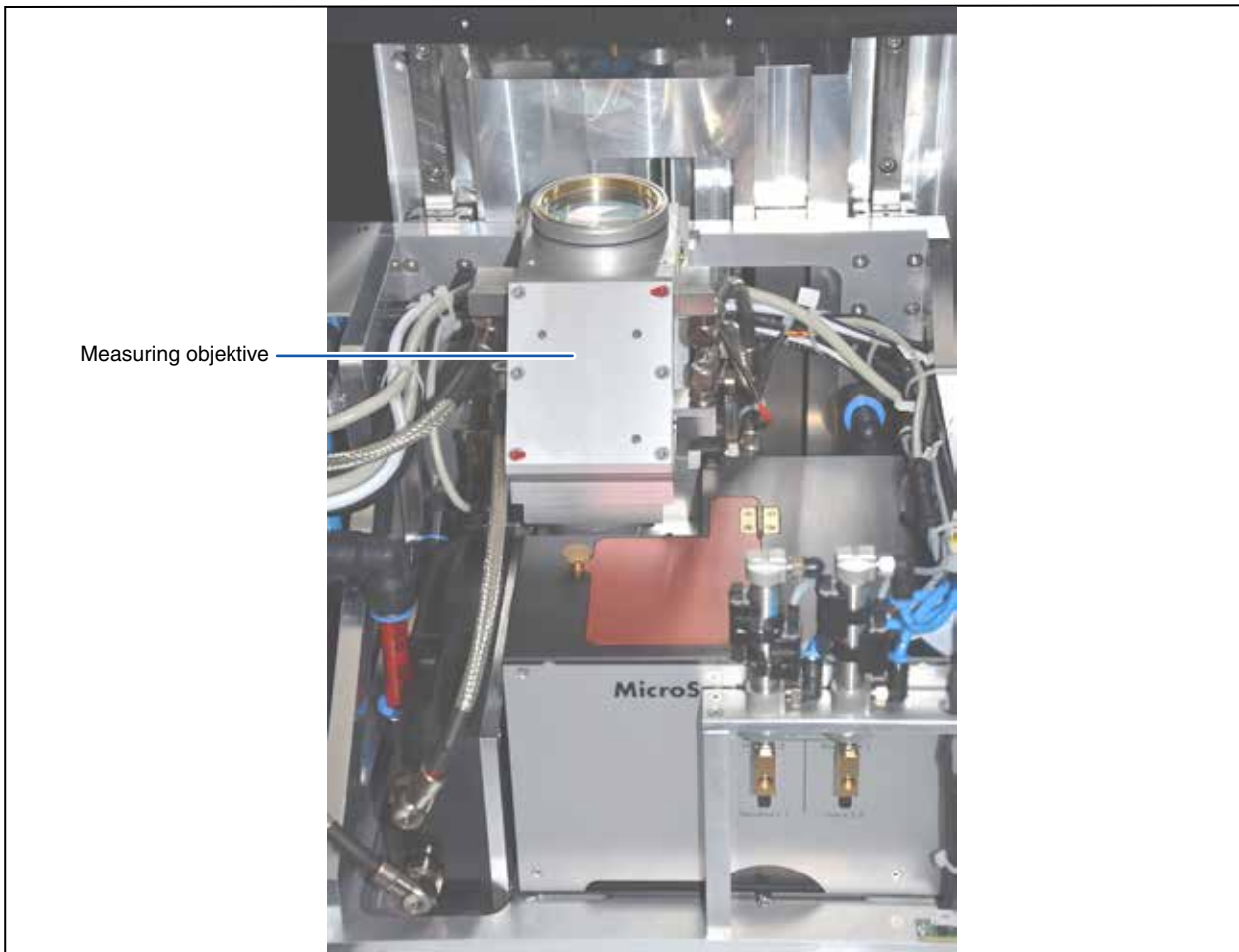

Fig.4.3: Measuring objektive in opened housing

4.1.2 Power measurement

The absorbed power is measured calorimetrically and is then analyzed with the software PMS 2.4. By means of the exact measurement of the temperature difference as well as the flow rate of the cooling water, the power of the absorbed laser beam can be determined exactly.

4.1.3 Power calibration

This function checks the calibration of the power measurement function. To perform a self-test, the system includes a heating element with a heat output of about 4 kW. The heating element warms the cooling water and the electrical power is determined calorimetrically. This value is then compared with the electrical power absorbed by the heating element.

4.2 Operation

The HP-MSM-I is operated by means of Ethernet with the PRIMES LaserDiagnosticsSoftware (LDS). For a fully automated beam monitoring the LDS can exchange data not only with the beam source but also with the control of the laser system. The measured beam parameters are compared with lower and upper limit values. A possible deviation from the target state is signaled by means of a “traffic light” color coding (green/yellow/red) in the user interface.

Moreover, semi-automatic (manual operation) in case of which selected script programs (script language Python V2.6) can be started. In this operating mode security-relevant activities (e.g. the closure of the shutter when the focusing head is positioned above the device) are confirmed by means of a manual switch.

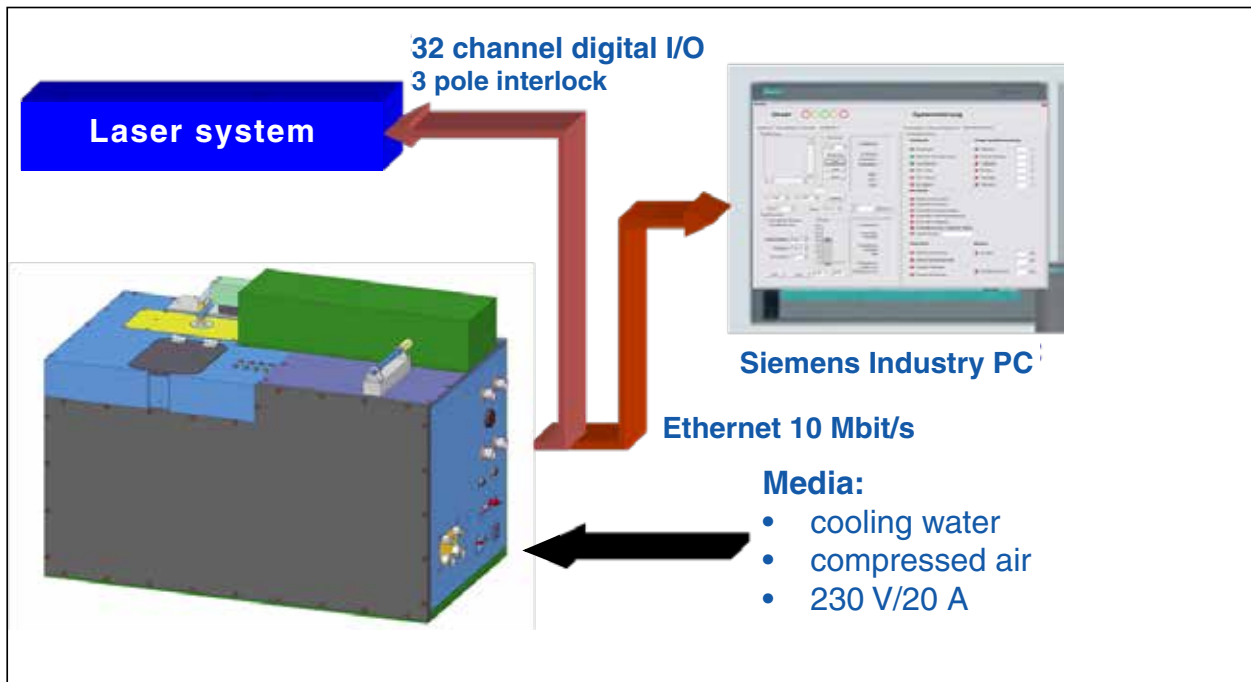

Fig.4.4: Connection with the system and an industry computer

4.3 Connections

The HP-MSM-I has the following electrical connections:

1. Mains connection 230 V, 20 A
2. Ethernet connection (10 Mbit/s) for the data transmission from the HP-MSM-I to the industry computer.
3. Two 3-pol safety circuit connections to stop the lasers in case of an error.
4. 2 PRIMES bus connections (RS485) for service purposes.
5. PLC in- and outputs (2x IN/2x OUT) for the system control.

Moreover, the connection of cooling water and compressed air is necessary for the operation.

4.4 Protective functions

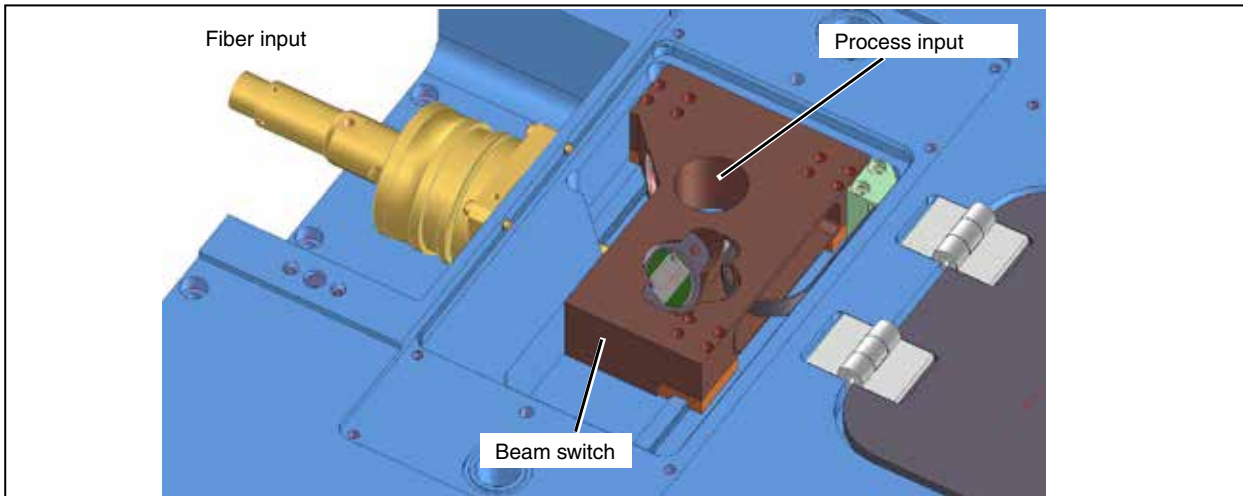

Fig.4.5: Internal beam switch (Display without reference plate)

By means of several mechanisms, the optical system is protected from contaminations:

- Pneumatic shutter at the process input
- Exchangeable protective window in front of the objective
- Overpressure in the airproof housing

As a protection from a possible contamination there is an exchangeable cartridge with four protective windows between the shutter and measuring objective which can be positioned in the beam path successively. Between the protective window and the housing aperture there is a closed area in which an air flow from the protective window into the exterior is generated by means of a crossjet.

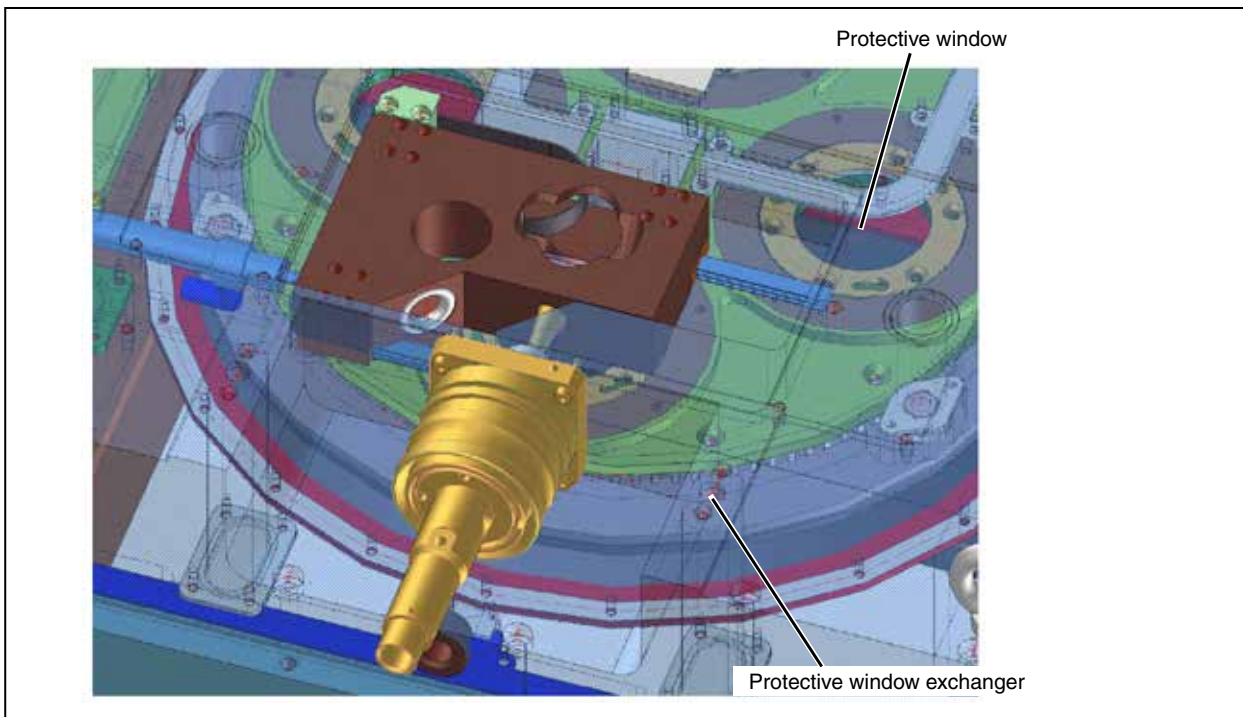

Fig.4.6: Protective window exchanger below the beam entrance

Moreover, two electrical safety circuits (Safety Interlock Fiber / Process) are integrated in order to protect the device from damages caused by a malfunction or an operating error (please see chapter 8.8 on page 33).

4.5 Display

Condition and position of the protective window are shown by means of eight LEDs. Two LEDs (one green one and one red one) are assigned to each protective window. After turning on the device, the LEDs light up, one of them flashes. If the green LED glows, the protective window is ok. If the red LED glows, the protective window is not ok.

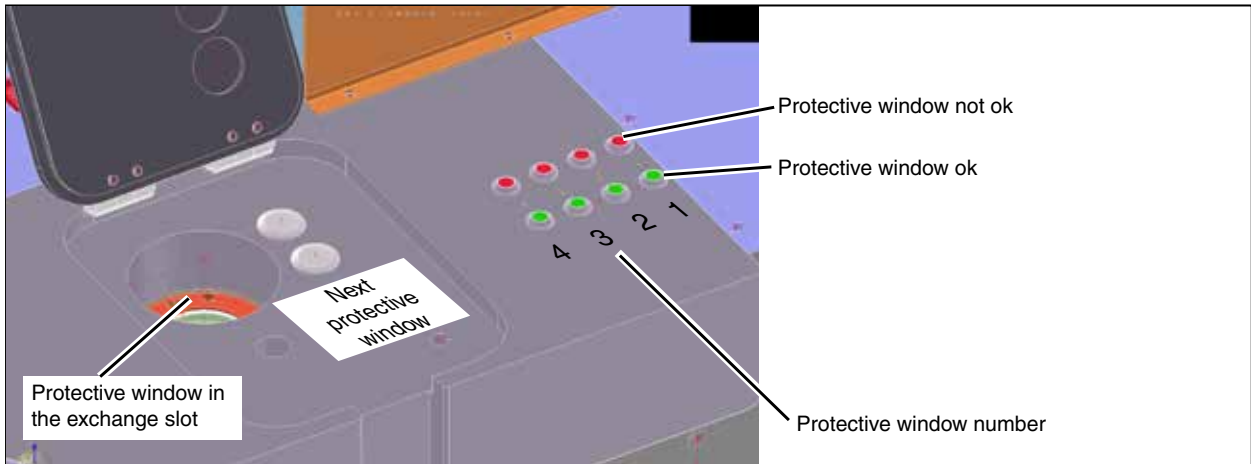

Fig.4.7: Inspection opening for the protective window exchange

The number of the protective window in the beam entrance (measurement position) is indicated by a slow flashing of the respective LED (in Fig.4.8 LED 2).

After opening the inspection flap, the number of the protective window inside the exchange slot is indicated by the fast flashing of the respective LED (in Fig.4.8 LED 4).

In case the protective window in the beam entrance is contaminated, the next clean window can be positioned by means of a pushbutton (next protective window) or the software. If all windows are contaminated, they have to be renewed (see chapter 12.1 on page 129).

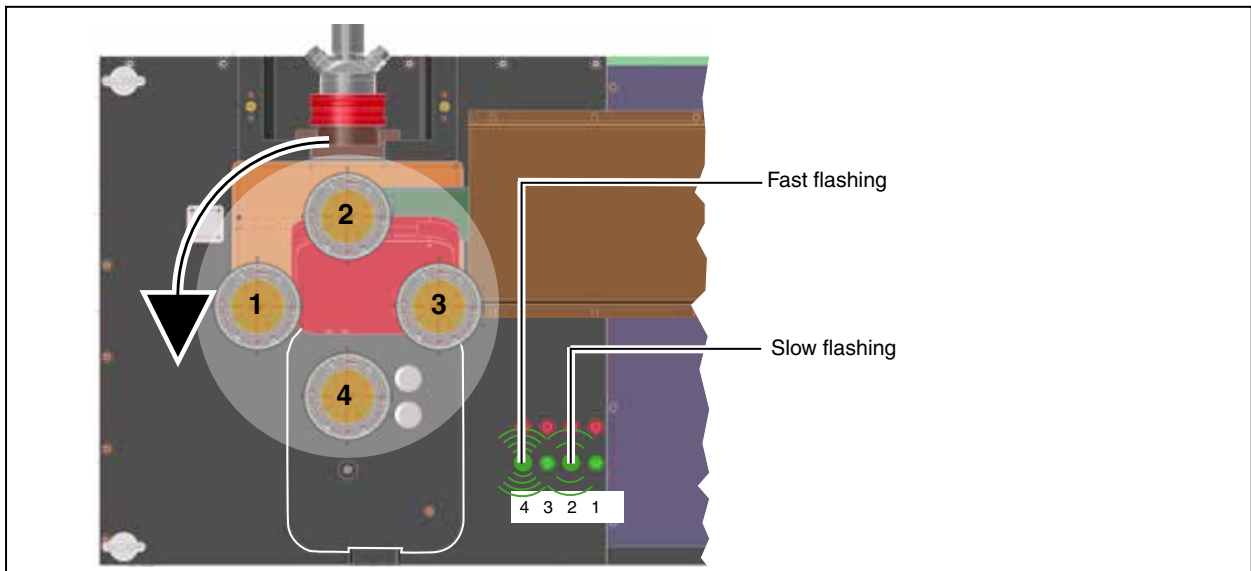

Fig.4.8: Arrangement of the protective windows and rotational direction of the exchanger (view from above)

LED condition	Meaning
Permanently glows green	Protective window is ok
Permanently glows red	Protective window is not ok
Slowly flashes green/red	Protective window is located in the beam entrance and is ok/not ok
Quickly flashes green/red	Protective window is located in the exchange slot and is ok/not ok

Tab.4.1: LED conditions of the protective window display

The condition of the protective windows is displayed in the software interface (please see chapter 9.9.3 on page 50). A protective window exchange can also be activated by means of the software (please see chapter „9.9.2 Pre-settings“ on page 48).

5 Overview Connector Panel

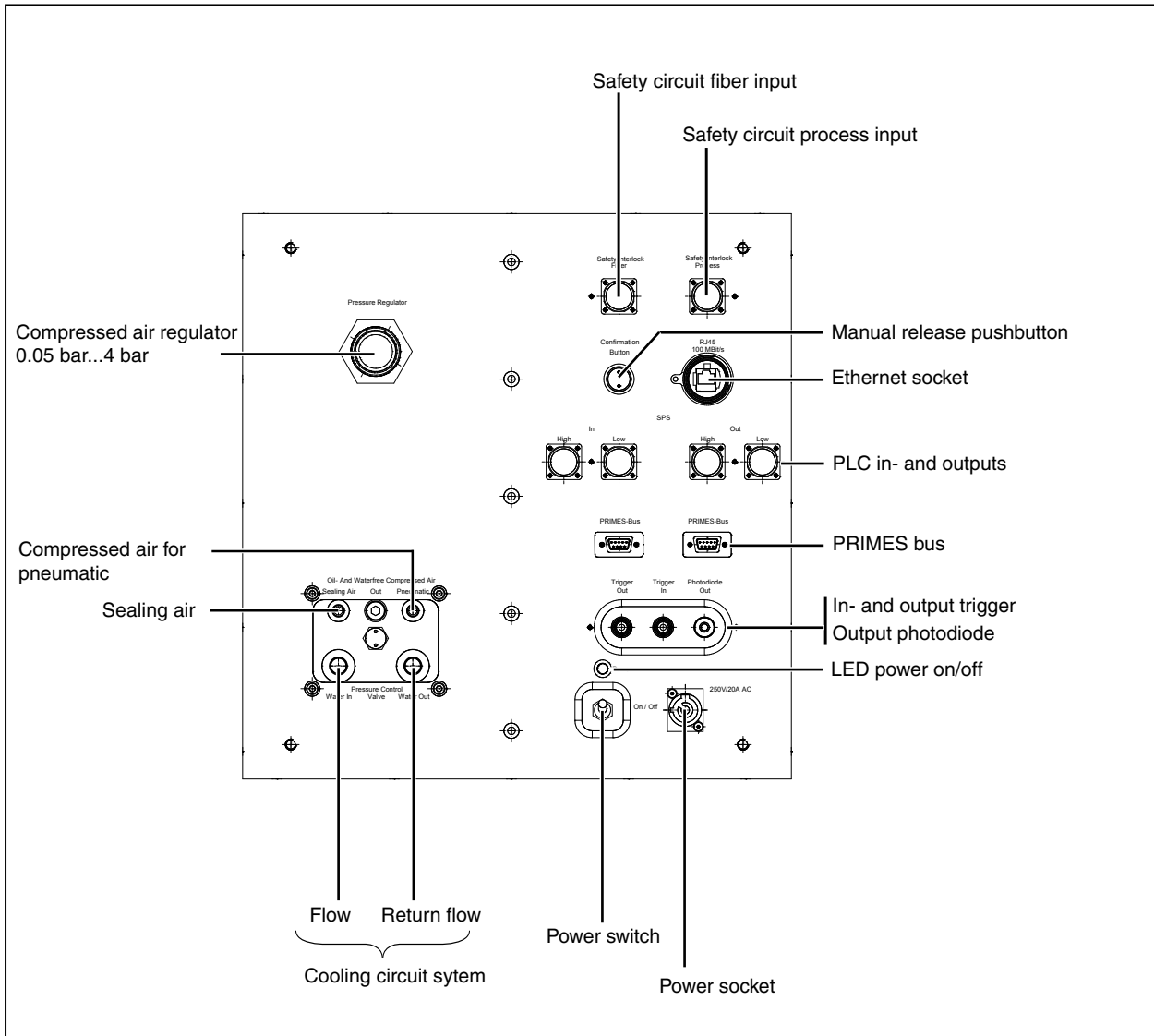

Fig.5.1: Connector panel of the HP-MSM-I

6 Transport and Installation

NOTICE

There is a danger of damage

Hard impacts or dropping can lead to a damage of optical parts.

- ▶ **Please be careful when transporting and installing the device!**

For the transport and the installation eyelets with a bore diameter of 20 mm are screwed in the housing. They are located opposite the mounting surface. However, they can also be screwed in somewhere else.



WARNING

There is a danger of injuries

The measuring device has a high weight (approx. 150 kg).

- ▶ **Please use appliances that are dimensioned accordingly as well as adequate hoists.**

6.1 Mounting Position and Attachment

Before mounting the device please check the space available, especially the space needed for the connection cables and – tube (please see chapter 14 on page 131).

The HP-MSM-I can be mounted in three different positions (2x horizontal, 1x vertical).



WARNING

There is a danger of injuries

If the measuring device is moved from the measured position, this can lead to scattered radiation.

- ▶ **When mounting the device, please ensure that it cannot be moved by unintended pushes or by pulling the cables.**

On three sides of the housing there are fastening threads M10 as well as adapter sleeves $\varnothing 12^{G6}$ for the mounting on a customer mounting (please see Fig.6.1). Please mount the housing with 6 screws each. With regard to the screws we recommend the strength class 8.8 as well as a tightening torque of 35 N·m (25.8 lbf ft).

NOTICE

There is a danger of damage

Too long screws can lead to a damage of the screw-in thread.

- ▶ **Please ensure that the fastening screws do not reach further into the housing than 12 mm.**

The total length of the screws depends on the dimensions of the customer mounting.

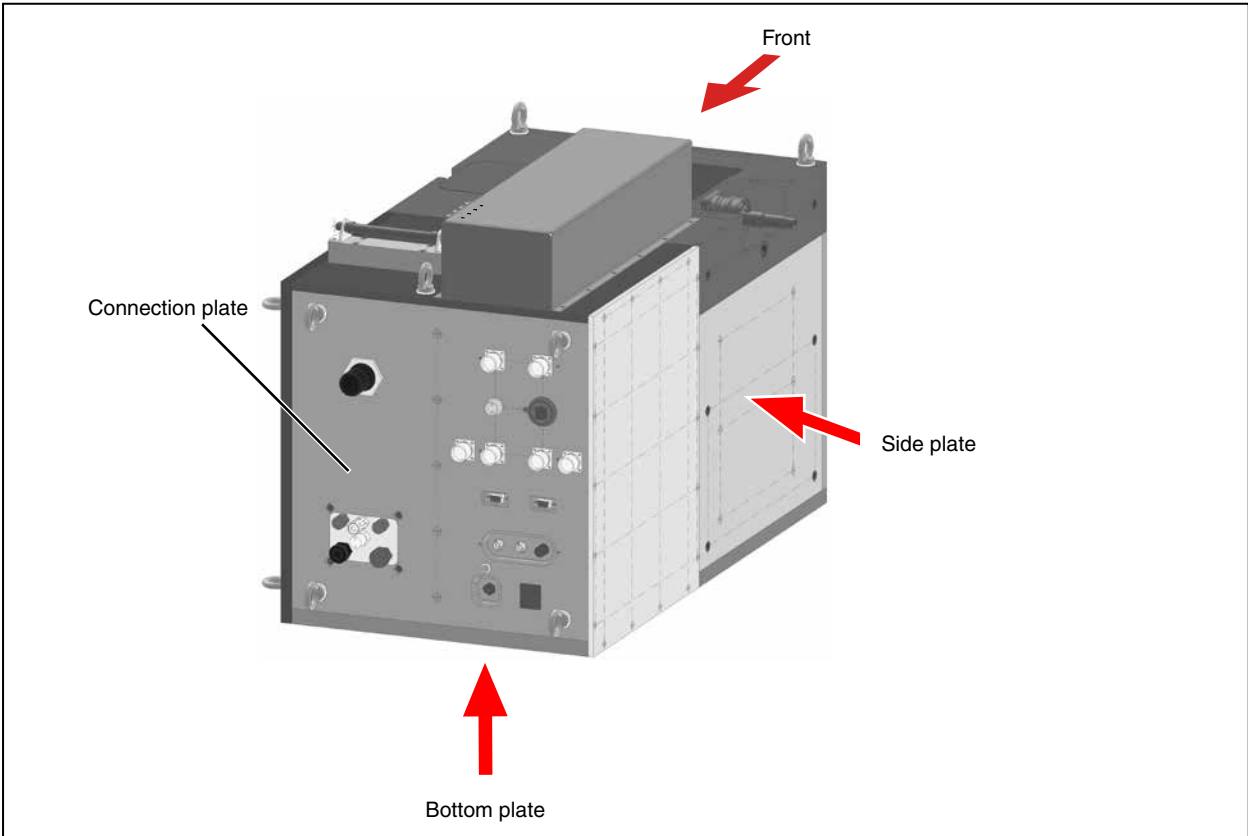

Fig.6.1: Mounting sides of the HP-MSM-I

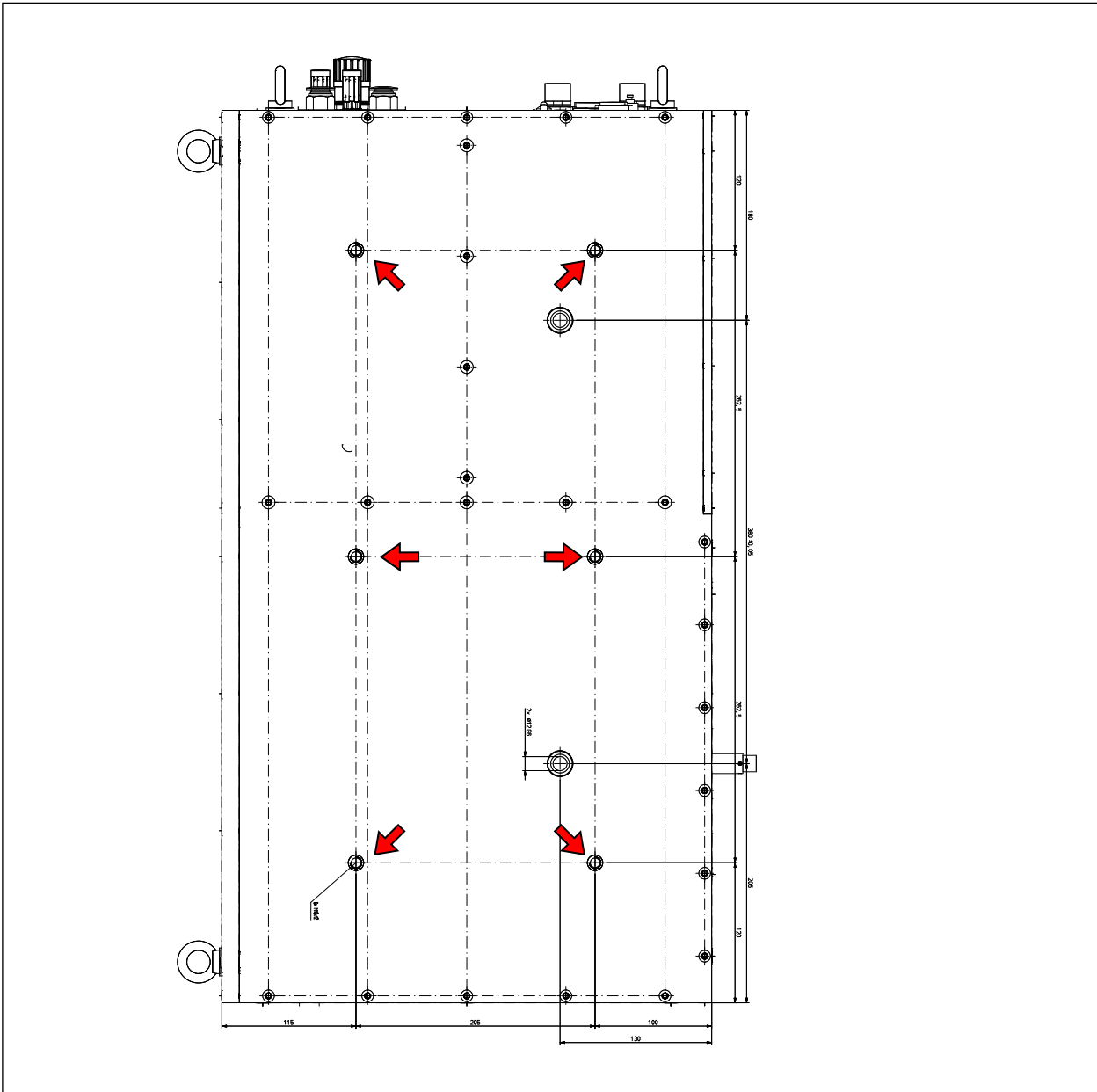

Fig.6.2: Fastening threads in the bottom plate

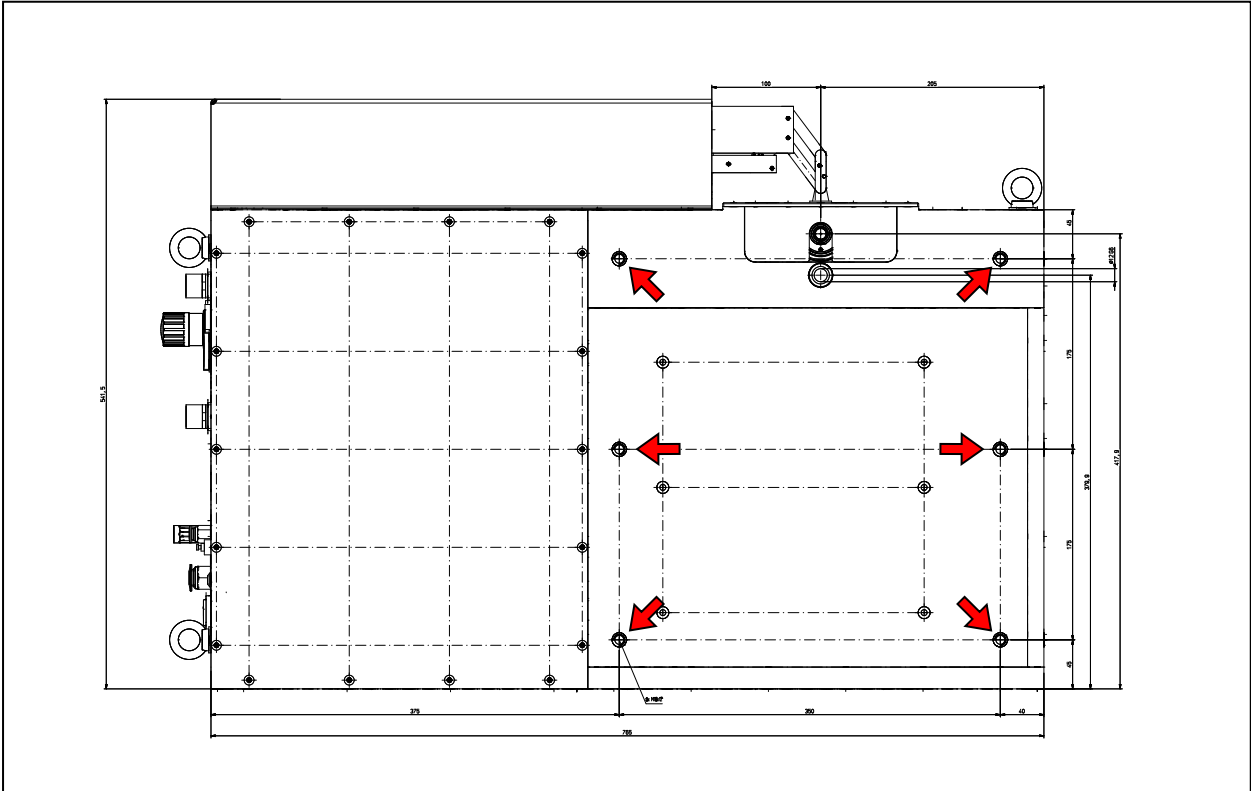

Fig.6.3: Fastening threads in the side plate

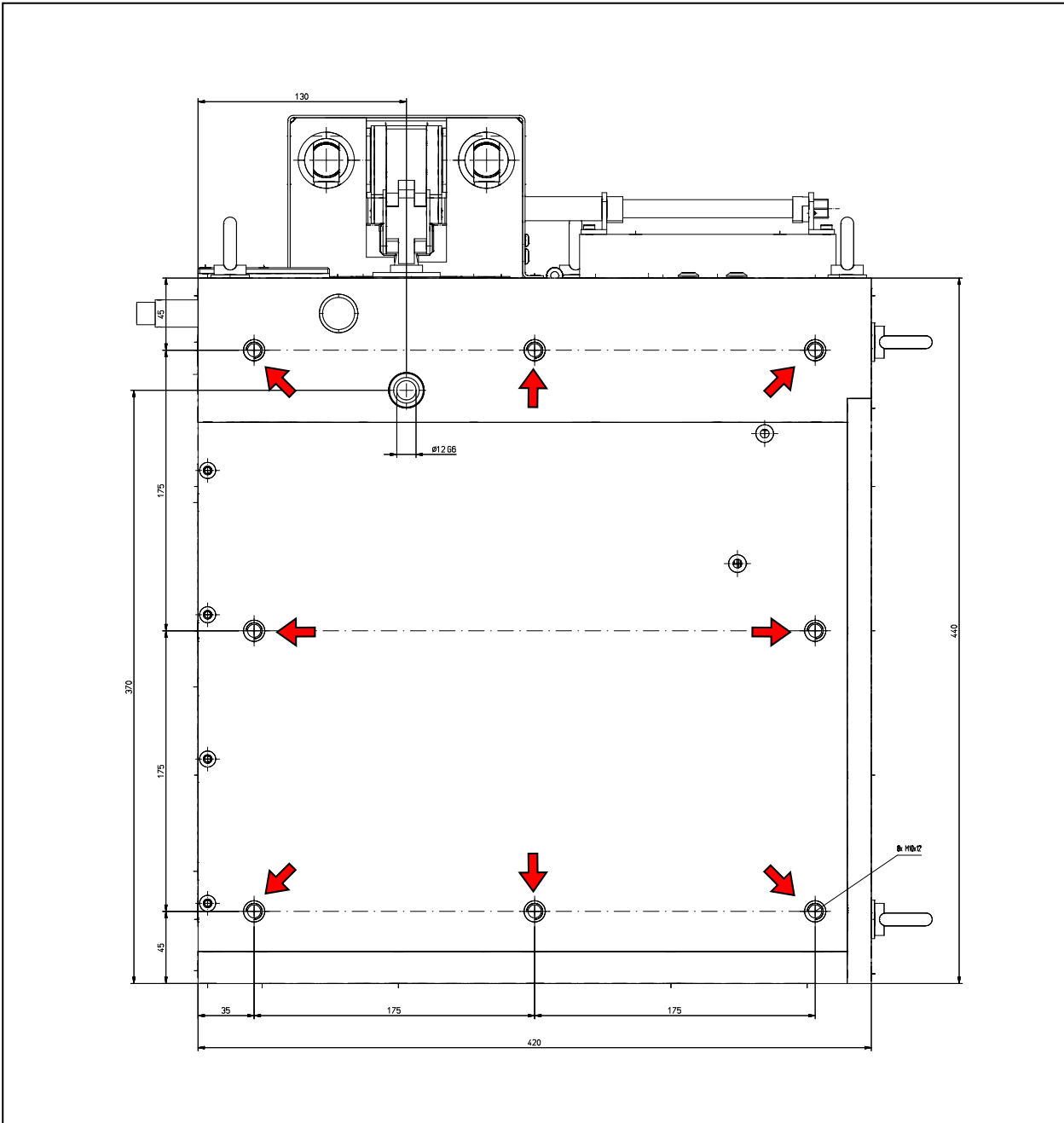

Fig.6.4: Fastening threads at the front

6.2 Alignment to the laser beam axis

When aligning the housing please ensure that the center of the laser beam as well as the aperture correspond to each other (please see Fig.6.5).

There is a reference plate in the housing which is mounted with the aperture and which is intended for the alignment. Around the aperture a reticule is grinded in.

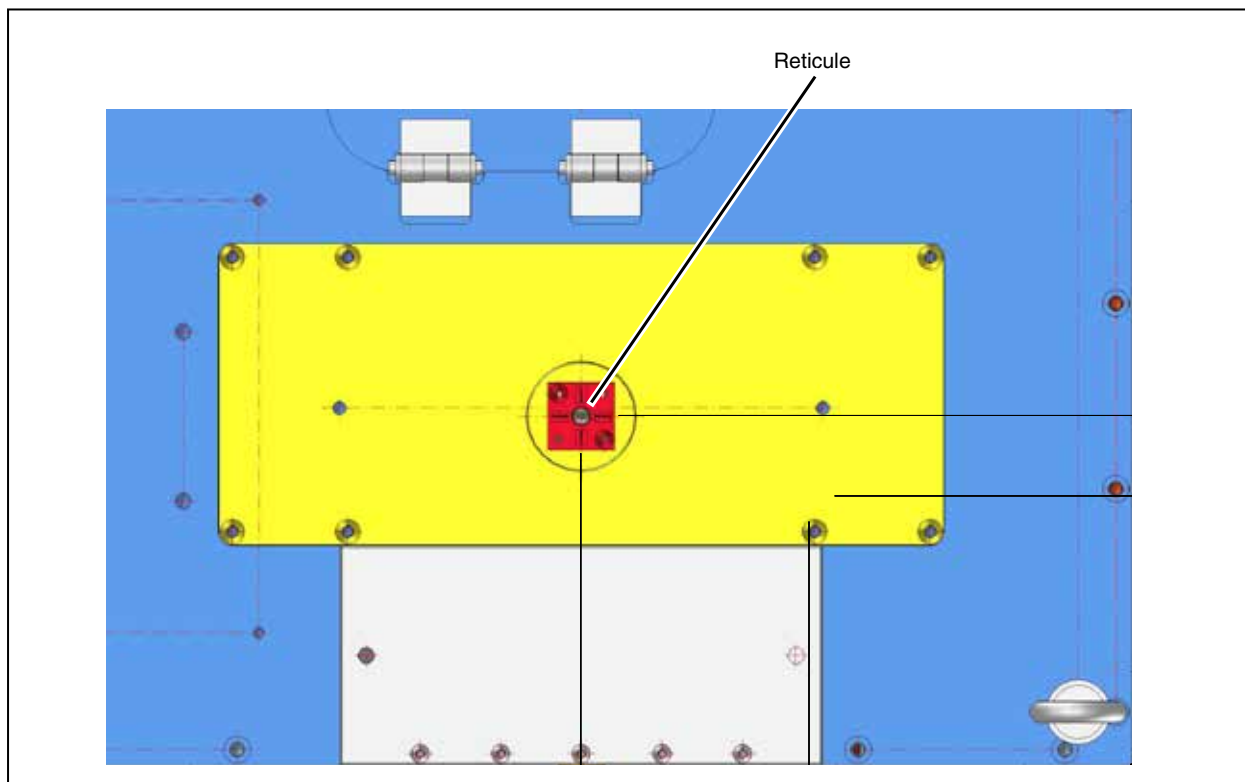

Fig.6.5: Reticule for the alignment (view from above)

7 Mechanical Connections

7.1 Cooling Circuit System

7.1.1 Requirements

The connections at the HP-MSM-I are intended for pipe diameters of 12 mm. For the reliable operation a water flow rate of at least 4 l/min is necessary. Please use cooling water with an electric conductance of > 300 μ S.



Do not add any additives to the cooling water, especially no anti-freeze agents. These could significantly change the thermal conductivity and this could then distort the measuring results..

Please only operate the HP-MSM-I in a non-condensing atmosphere. The temperature of the cooling water must not be below the ambient temperature.

Please only cool the device during the measuring operation. We recommend to start the cooling approx. 2 minutes before the measurement and to end it approx. 1 minute after the measurement.

7.1.2 Connecting

- Please remove the sealing plugs of the cooling circuit and make sure that you keep them in a safe place
 - Please connect the flow (Water In) as well as the return flow (Water Out) of the device.
-

NOTICE

There is a danger of damage due to foreign material

If you work with sealing tape (e.g. Teflon or manila) when installing the cooling circuit you need to ensure that no parts get into the turbine! They could inhibit the flow or stop it completely.

- ▶ **Please rinse the pipe system thoroughly before connecting it.**
-

NOTICE

There is a danger of damage due to contact corrosion

The aquiferous parts in the device consist of copper, brass or stainless steel. A connection to pipes made of aluminum could lead to a corrosion of the aluminum due to different chemical potentials.

- ▶ **Do not connect the device with a supply network made of aluminum.**
-

7.2 Compressed air

The compressed air is required in order to

- open or close the shutter
- generate overpressure in the housing to prevent contaminations
- move the beam switch
- provide the positioning cylinder of the objective

Please connect the compressed air supply by means of a plastic hose with an external diameter of 6 mm. A pressure of 4 bar is needed. User-specific modifications are possible.

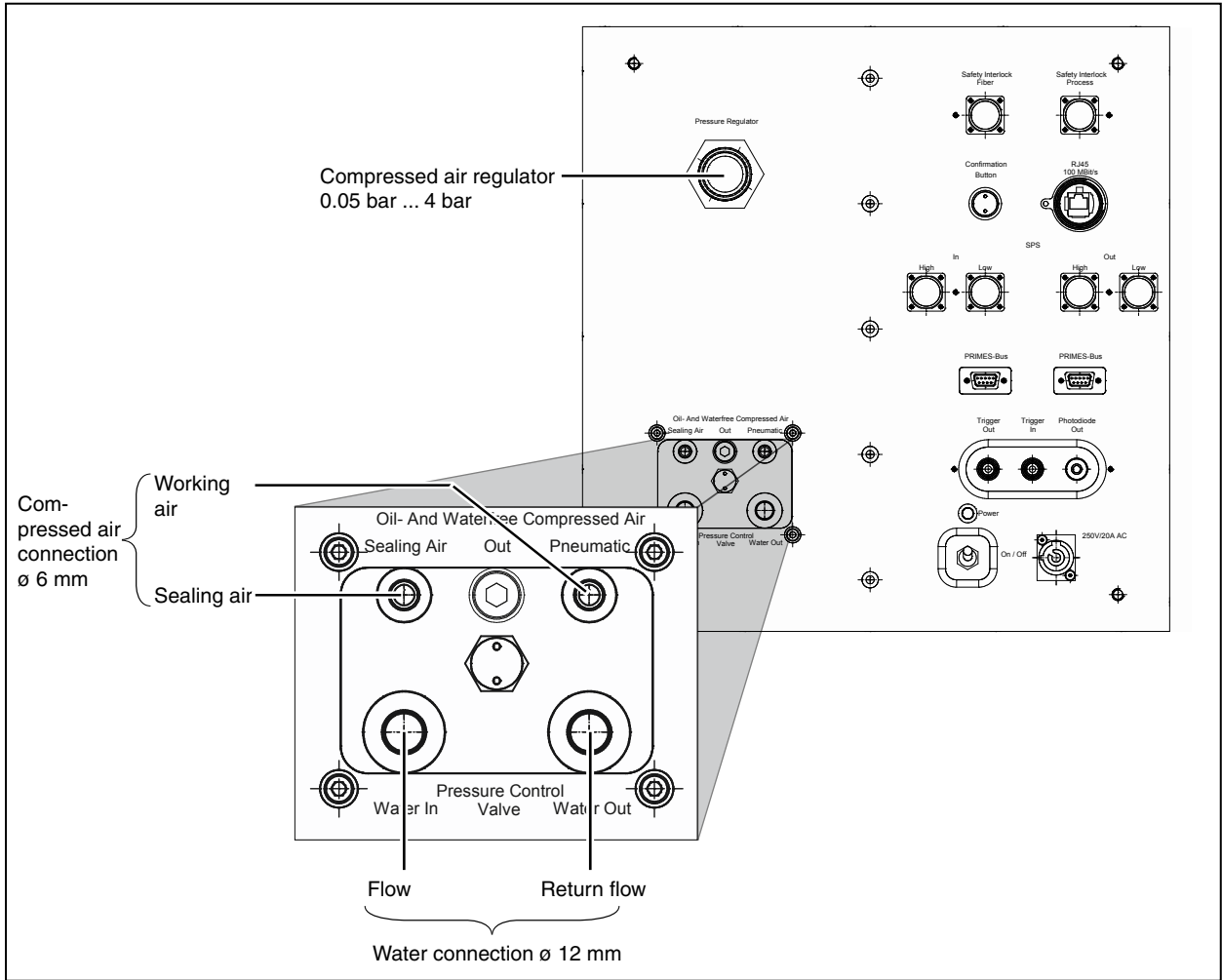

Fig.7.1: Connection of compressed air and cooling water

7.3 Fiber connection

NOTICE

There is a danger of damage due to dirt particles in the environment.

- ▶ Bring the beam switch into position “beam entrance”, before you connect the fiber or disconnect it. The same applies for the removal of the protective cap at the fiber input.

7.3.1 Changing the fiber adapter

There are three fiber adapters included in the scope of delivery. The device will be delivered with one mounted fiber adapter.

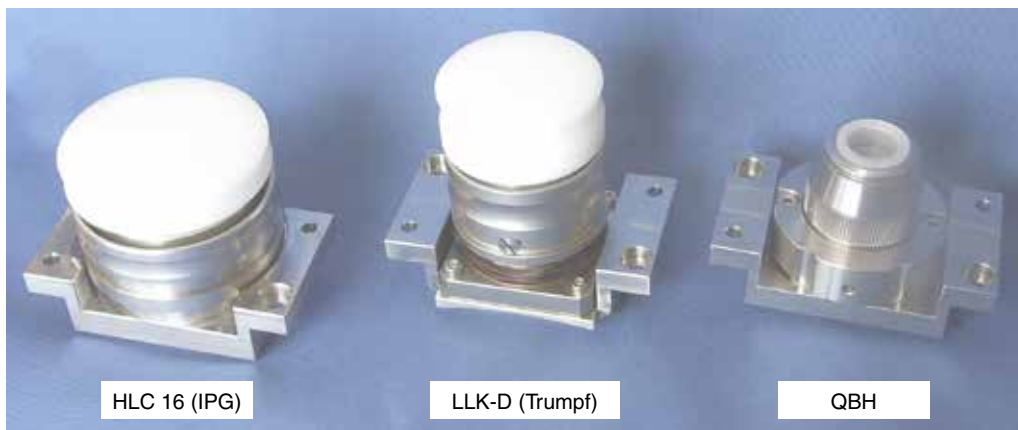

Before exchanging the fiber adapter, the following conditions need to be fulfilled:

6. The shutter is closed.
7. The sealing air is switched on.
8. The beam switch is in the position „Beam measurement“.

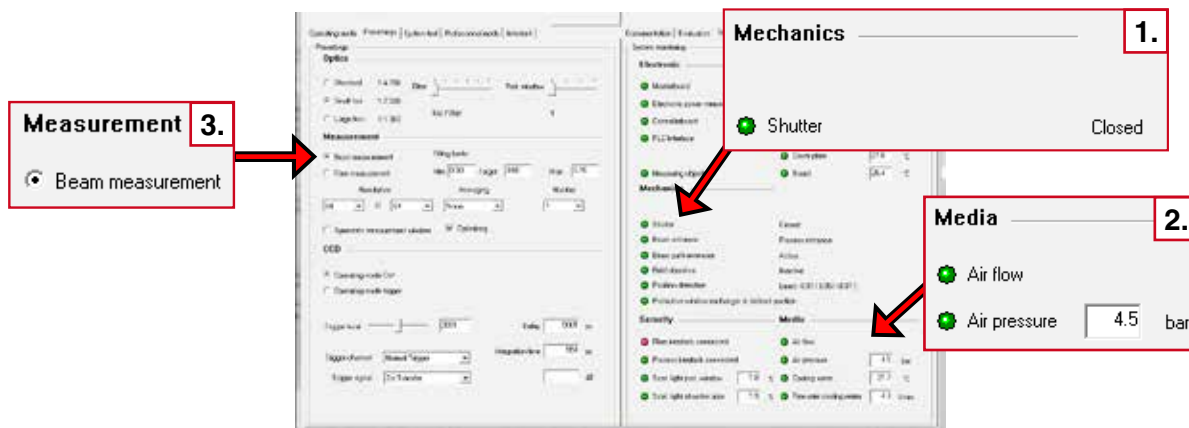

Fig.7.2: Graphical user interface of the LaserDiagnoseSoftware

8 Electrical connections

8.1 Power supply

Please insert the panel connector of the power cable (included in the scope of delivery) into the power socket on the right of the power switch and turn it 30° clockwise until the security slider engages. Connect the HP-MSM-I with an AC voltage of 230 V/20 A by means of the safety plug.

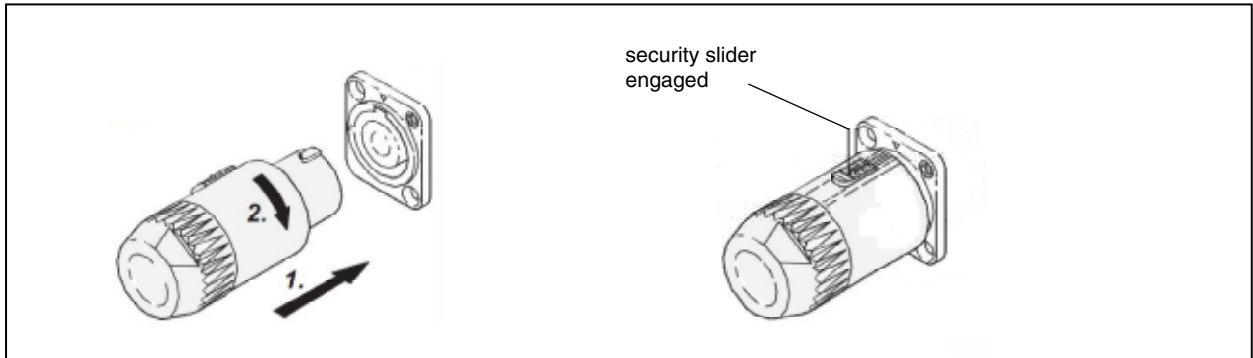

Fig.8.1: Power supply connector

8.2 Trigger In/Out

BNC sockets, 5 V TTL level

8.3 Photodiode Out

BNC socket, output of the scattered light LED.

8.4 PRIMES Bus

Pole diagram D-Sub socket, 9-pole (view connector side)		
	Pin	Function
	1	GND
	2	RS-485 (+)
	3	+24 V
	4	Unassigned
	5	Unassigned
	6	GND
	7	RS-485 (-)
	8	+24 V
	9	Unassigned

Tab.8.1: D-Sub socket, PRIMES bus

8.5 PLC IN/OUT

The HP-MSM-I has 32 input and 32 output lines which can be connected with the system via the plugs IN (Hi/Lo) or – respectively – OUT (Hi/Lo).

The signal level lies at +24 V (high level).

Some lines of the inputs and outputs have – depending on the signals on the more significant lines - a double assignment with regard to their functionality.

8.5.1 Output line, plug OUT/LO (Low-Word)

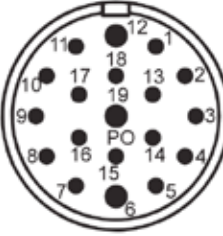
Pole diagram plug, 19 poles	Pin	Function
<p>Coninvers RC-19P1N126300 (View connector side)</p> 	1	State _{OUT 0} / Data _{OUT 0}
	2	State _{OUT 1} / Data _{OUT 1}
	3	State _{OUT 2} / Data _{OUT 2}
	4	State _{OUT 3} / Data _{OUT 3}
	5	State _{OUT 4} / Data _{OUT 4}
	6	Ground-connection
	7	State _{OUT 5} / Data _{OUT 5}
	8	State _{OUT 6} / Data _{OUT 6}
	9	State _{OUT 7} / Data _{OUT 7}
	10	State _{OUT 8} / Data _{OUT 8}
	11	State _{OUT 9} / Data _{OUT 9}
	12	Ground-connection
	13	State _{OUT 10} / Data _{OUT 10}
	14	State _{OUT 11} / Data _{OUT 11}
	15	State _{OUT 12} / Data _{OUT 12}
	16	State _{OUT 13} / Data _{OUT 13}
	17	State _{OUT 14} / Data _{OUT 14}
	18	State _{OUT 15} / Data _{OUT 15}
	19	Unassigned
Housing	Ground-connection	

Tab.8.2: PLC plug OUT/Lo

8.5.2 Output lines, plug OUT/Hi (High-Word)

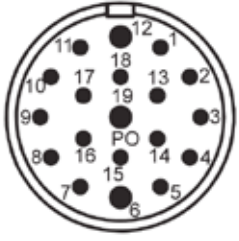
Pole diagram plug, 19 poles Coninvers RC-19P1N126300 (View connector side)	Pin	Function
	1	State _{OUT 16} / Addr _{OUT 0}
	2	State _{OUT 17} / Addr _{OUT 1}
	3	State _{OUT 18} / Addr _{OUT 2}
	4	State _{OUT 19} / Addr _{OUT 3}
	5	State _{OUT 20} / Addr _{OUT 4}
	6	Ground-connection
	7	State _{OUT 21} / Addr _{OUT 5}
	8	State _{OUT 22} / Addr _{OUT 6}
	9	State _{OUT 23} / Addr _{OUT 7}
	10	State _{OUT 24} / Addr _{OUT 8}
	11	State _{OUT 25} / Addr _{OUT 9}
	12	Ground-connection
	13	Reserved
	14	Reserved
	15	Reserved
	16	Reserved
	17	Ack (Acknowledge)
	18	Alive
	19	Unassigned
Housing	Ground-connection	

Tab.8.3: PLC plug OUT/Hi

Functions:

Reserved

Reserved output lines (currently without function).

Acknowledge

With this output bit the HP-MSM-I signals the validity of the data lines.

Only as long as this pin is on the low level, the data on the output lines of the HP-MSM-I are valid. Moreover, this line signals that the valid data were scanned in on the input line.

Alive

Alternating output lines. Signals the system an operative HP-MSM-I. The Alive line changes the voltage level at least every 5 seconds (> 0.2 Hz). It is changed from 0 V to 24 V and back to 0 V again. If this line does not change its signal condition anymore, a power-up or – respectively – a reboot should be carried out.

Data register of the output side

Read access

In the data registers on the output side of the HP-MSM-I flags are displayed which cannot be issued via the status bits. Furthermore, values of the HP-MSM-I can be transmitted to the system by means of these data registers.

Write access

With regard to the transmission of a command – in case of a write access – the output lines are used for the status bits.

8.5.3 Input lines, plug IN/Lo (Low-Word)

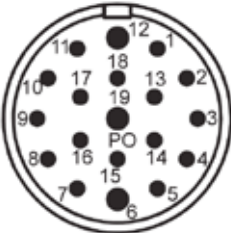
Pole diagram plug, 19 poles	Pin	Function
<p>Coninvers RC-19P1N126300 (View connector side)</p> 	1	State _{IN 0} / Data _{IN 0}
	2	State _{IN 1} / Data _{IN 1}
	3	State _{IN 2} / Data _{IN 2}
	4	State _{IN 3} / Data _{IN 3}
	5	State _{IN 4} / Data _{IN 4}
	6	Ground-connection
	7	State _{IN 5} / Data _{IN 5}
	8	State _{IN 6} / Data _{IN 6}
	9	State _{IN 7} / Data _{IN 7}
	10	State _{IN 8} / Data _{IN 8}
	11	State _{IN 9} / Data _{IN 9}
	12	Ground-connection
	13	State _{IN 10} / Data _{IN 10}
	14	State _{IN 11} / Data _{IN 11}
	15	State _{IN 12} / Data _{IN 12}
	16	State _{IN 13} / Data _{IN 13}
	17	State _{IN 14} / Data _{IN 14}
	18	State _{IN 15} / Data _{IN 15}
	19	Unassigned
Housing	Ground-connection	

Tab.8.4: PLC plug IN/Lo

8.5.4 Input lines, plug IN/Hi (High-Word)

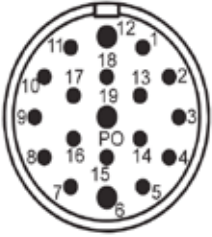
Pole diagram plug, 19 poles Coninvers RC-19P1N126300 (View connector side)	Pin	Function
		1
2		State _{IN 17} / Addr _{IN 1}
3		State _{IN 18} / Addr _{IN 2}
4		State _{IN 19} / Addr _{IN 3}
5		State _{IN 20} / Addr _{IN 4}
6		Ground-connection
7		State _{IN 21} / Addr _{IN 5}
8		State _{IN 22} / Addr _{IN 6}
9		State _{IN 23} / Addr _{IN 7}
10		State _{IN 24} / Addr _{IN 8}
11		State _{IN 25} / Addr _{IN 9}
12		Ground-connection
13		Reserved
14		Automatic
15		Reboot
16		Abort
17		R / !W (Read / NotWrite)
18		Strobe
19		Unassigned
Housing	Ground-connection	

Tab.8.5: PLC plug IN/Hi

Functions:

Reserved

Reserved input lines (currently without function).

Automatic

When it comes to an automated operation of the HP-MSM-I via the system, it is signaled via the input line 14 at the PLC plug whether an automated operation is desired. A correct operation of the HP-MSM-I via the system can only be ensured in case of the automated operation (please see „Automatic operating mode“ on page 95).

In order to ensure that the HP-MSM-I switches to the automated mode correctly after the device has been prepared for the operation, this line needs to be connected with 24 V.

Reboot

When connecting 24 V the internal voltage supply of the electronics is interrupted. This function can be used for a restart of the electronics.

Abort

The running measurement is cancelled as soon as this line is connected with 24 V. This procedure can take several seconds until the actual cancellation of the running measurement is effected. This line is only needed for the cancellation of running measurements, not for the cancellation of running actions or – respectively – commands in one of the command registers (Cmd1 and Cmd2).

If this control was recognized correctly and the cancellation is initiated bit 9 (AbtPgrs) is set in the register 00001 (Status2) (please see chapter 11.4.2 on page 115). The abort signal now has to be reset.

R / !W (Read / NotWrite)

This bit signals the HP-MSM-I whether the created data form a command (write access) or an enquiry (read access).

In case of a read access on the part of the laser system the signal status at the data lines of the inputs does not have any influence.

Strobe

Initiates the actual data transfer from the system to the HP-MSM-I. With this line the system signals that the data at the inputs of the HP-MSM-I are valid. In case of a read access the low level on this line means that the output lines of the HP-MSM-I have to be valid.

Data register of the input side

The data register of the input side of the HP-MSM-I is needed for the inquiry of flags which cannot be issued via the status bits. Moreover, the data register offers the possibility to read out values of the HP-MSM-I with the system. (read access).

Via the data register commands to the HP-MSM-I are transmitted (write access) as well.

When it comes to the data transmission the input lines can be separated into address and data lines. By means of the address lines the different data registers can be read out and / or can be written.

8.6 Ethernet connection (RJ-45)

Please connect the device by means of a crossover with the PC or by means of a patch cable with the network.

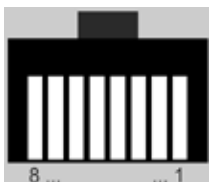

Fig.8.2: Ethernet connector socket

8.7 Confirmation Button

Connection for the release button. It is needed for the manual operation (please see chapter 10.1 on page 78) in order to confirm a communication from the software.

8.8 Safety Circuit (Safety Interlock Process/Fiber)

Two safety circuits protect the measuring device from damages caused by a wrong handling by turning off the laser beam in case of an error status within the device.

Two safety circuits protect the measuring device from damages caused by a wrong handling by turning off the laser beam in case of an error status within the device.

NOTICE

Danger of damage

If the safety circuit is not connected, a possible error could damage the device due to an overheating or the still closed shutter could be destroyed by the laser beam.

- ▶ **When connecting the laser control with the pins 1 to 4 and 3 to 6 please ensure that - in case of a interruption of this connection – the laser is turned off. (please see circuit diagram, Fig.8.3).**

The following conditions open the safety circuit:

- The shutter is closed
- No or not enough cooling water
- Not enough pressure
- Not enough flushing air
- Protective window changer not in position
- Excess temperature at the absorber or one of the boards
- The beam switch is in the wrong position
- The interlock plug is not connected (see Tab.8.6, Pin 8)

When plugging the fiber, the safety circuit of the HP-MSM-I is additionally connected with the safety circuit included in the fiber plug. This means that – by means of the fiber plug – the laser can be turned off automatically via the fiber safety circuit when in operation.

Safety Interlock (Pin assignment Process/Fiber are identical)		
Pin arrangement (view plug side)	Pin	Assignment
	1	
	2	If inoperable, bridged with Pin 1
	3	If operable, bridged with Pin 1
	4	
	5	If inoperable, bridged with Pin 4
	6	If operable, bridged with Pin 4
	7	Unassigned
	8	24 V input (recognition of the interlock plug)
	9	GND
	Housing	GND
Plug designation	EPIC M23A1 flush-mounting box + pin insert 8+1 Manufacturer: Lapp, series EPIC Circon M23 – part no.: 720040000 and 73002744 – order no. at RS Components: 219-497	
Suitable cable socket	EPIC M23A1 cable plug + socket 8+1 part no.: 44420037 and 73002740 – order no. at RS Components: 219-481	

Tab.8.6: Plug Safety Interlock

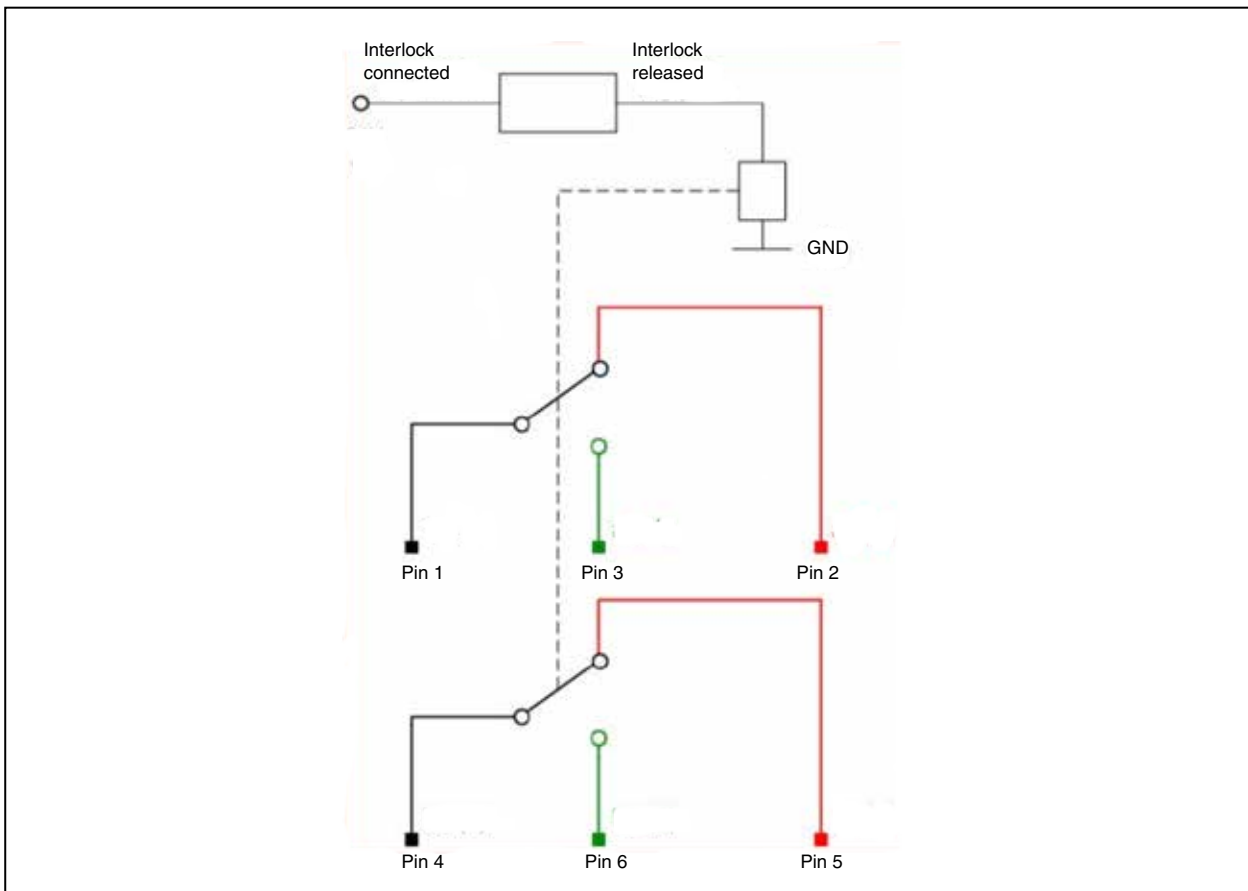

Fig.8.3: Circuit diagram of the interlock plug

9 Software

For the operation of the HP-MSM-I the PRIMES program “LDS” (LaserDiagnosticsSoftware) has to be installed on the computer. The program can be found on the attached CD.

9.1 System requirements

Operating system: Windows® 98/XP/Vista/7
Processor: Intel® Pentium® 1 GHz (or comparable processor)
Free disc space: 15 MB
Monitor: 19“ screen diagonal is recommended, resolution at least 1024x768

9.2 Installing the software

The installation of the software is effected menu-controlled by means of the attached CD. Please start the installation by double-clicking on the installation file “Setup.exe” and follow the given instructions.

The installation software stores the main program “LaserDiagnosticsSoftware.exe” – if not stipulated differently – in the directory “Program/PRIMES/LDS”. Moreover, the settings-file “laserds.ini” is copied into this directory. In “laserds.ini” the setting parameter for the PRIMES-LaserDiagnosticsSoftware are deposited.

9.3 Starting the Software

After the completion of the installation, the program can be started by clicking the PRIMES symbol in the new start menu group or the desktop shortcut .



When starting the software for the first time, please choose the option **Visualize measurement from file**. Otherwise, an error message will appear which reports a missing connection to the device.

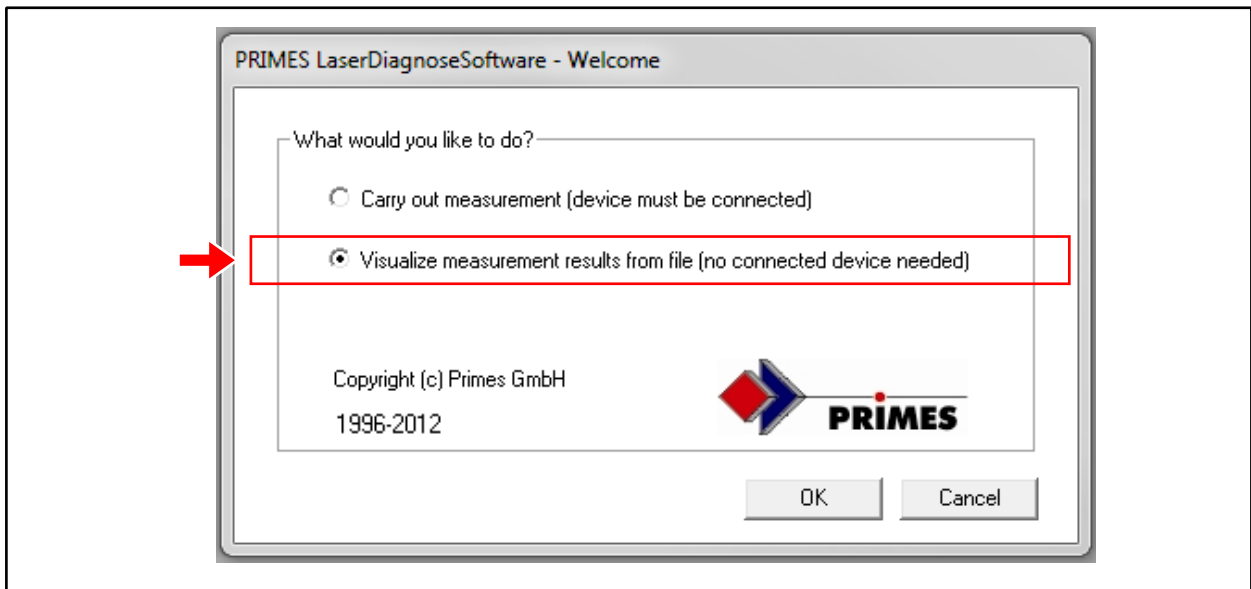
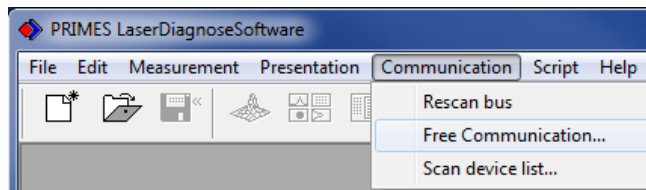

Fig.9.1: Start window of the LaserDiagnosticSoftware

9.4 Entering the device address

1. Please click *Communication* in the menu list and then choose *Free Communication*.



On the connection side of the HP-MSM-I there is a sticker on which the IP address of the device as well as the PLC board can be found. These addresses have to be entered in the dialogue window *Free Communication*.

2. Please choose *TCP* and *Second IP*.
3. Please enter the device address in the first IP-field and the PLC address in the second IP-field.
4. Please click the button *Connect* and then *Store*.

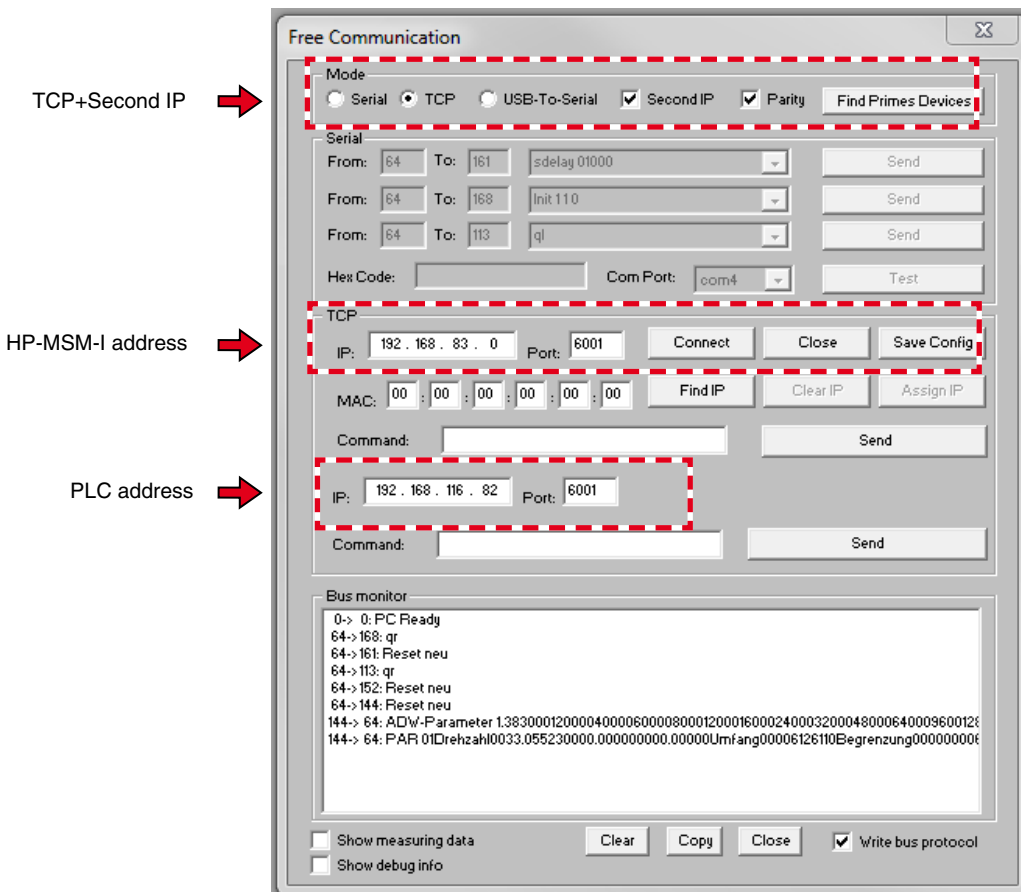

9.5 User level ****OPTION****

From version 2.9.034 on, the LaserDiagnosticSoftware is available with a user level control. There are different user levels which are activated with the corresponding password. This enables you to limit the control options in the software and to adapt them to the requirements of the operation. The following user levels are defined:

User level	Password	Access to function
Operator (Op)	No password	strongly limited
Controller (Co)	l6wtx	limited
Expert (Ex)	upon request	mostly unlimited
Professional (Pro)	upon request	mostly unlimited

Tab.9.1: Passwords for user levels

When starting the software you can activate the user level control in the launch window (Click on **Change user level**, see Fig.9.2). If you do not use this option or if a false password is typed in, the software automatically starts with the lowest authorisation level "Operator". This also applies for a system control start-up.

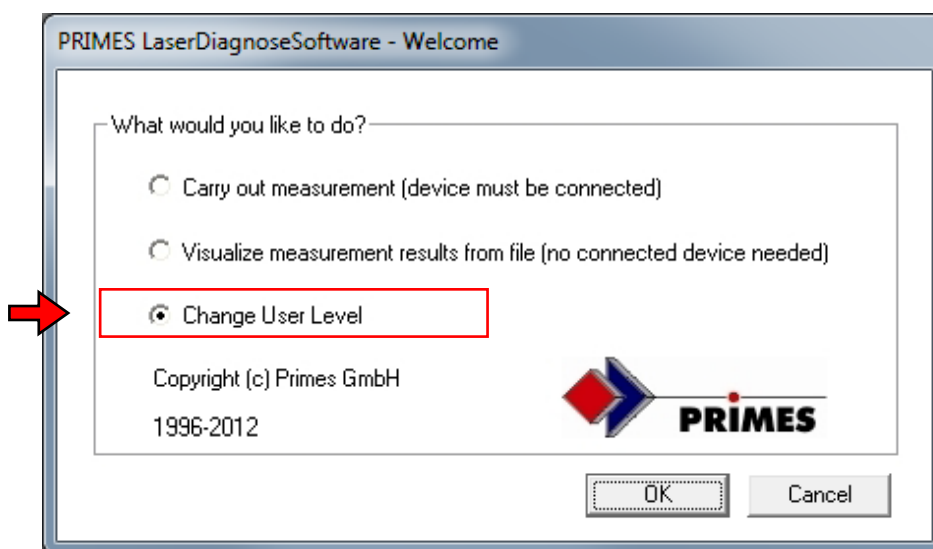

Fig.9.2: Changing the user level

You can also change the user interface during the operation (menu **Edit** → **Change User Level...**). If either the password is entered incorrectly or if no password is entered at all, you are again signed in as Operator.

The user level "Operator" is for instance intended for the application in the production. Although the execution of scripts is allowed in order to enable an automated sequence control, advanced settings of connected devices or a manual storage of the measuring results are, however, not possible.

The assignment of the permitted activities for the selected user level can be seen in Tab.9.2.

Op = Operator
 Co = Controller
 Ex = Expert
 Pro = Professional

Software functions		No device connected	Device connected	Measurement	Loaded measurement
File	New	Co, Ex, Pro	Co, Ex, Pro	Co, Ex, Pro	Co, Ex, Pro
	Open...	Co, Ex, Pro	Co, Ex, Pro	Co, Ex, Pro	Co, Ex, Pro
	Close				Co, Ex, Pro
	Close all				Co, Ex, Pro
	Save			Co, Ex, Pro	Co, Ex, Pro
	Save as...			Co, Ex, Pro	Co, Ex, Pro
	Export...				Ex, Pro
	Load measurement preferences...		Co, Ex, Pro	Co, Ex, Pro	
	Save measurement preferences...		Co, Ex, Pro	Co, Ex, Pro	
	Protocol...		Co, Ex, Pro	Co, Ex, Pro	
	Print...				Co, Ex, Pro
	Print preview...				Co, Ex, Pro
	Recently opened files	Co, Ex, Pro	Co, Ex, Pro	Co, Ex, Pro	Co, Ex, Pro
	Exit	Co, Ex, Pro	Co, Ex, Pro	Co, Ex, Pro	Co, Ex, Pro
Edit	Copy				
	Clear plane				
	Clear all planes				
	Change User Level...	Co, Ex, Pro	Co, Ex, Pro	Co, Ex, Pro	Co, Ex, Pro
Measurement	Environment...	Co, Ex, Pro	Ex, Pro	Ex, Pro	Ex, Pro
	Sensor parameters		Ex, Pro	Ex, Pro	
	Beamfind settings		Ex, Pro	Ex, Pro	
	CCD info...				
	CCD Settings...				
	LQM - Adjustment...				
	Power Measurement...				
	Single ...		Co, Ex, Pro	Co, Ex, Pro	
	Caustic...		Co, Ex, Pro	Co, Ex, Pro	
	Start Adjust-Mode				
Option...	Co, Ex, Pro	Co, Ex, Pro	Co, Ex, Pro	Co, Ex, Pro	
Presentation	False colors...			Co, Ex, Pro	Co, Ex, Pro
	False colors (filtered)...			Co, Ex, Pro	Co, Ex, Pro
	Isometry...			Co, Ex, Pro	Co, Ex, Pro
	Isometry 3D...			Co, Ex, Pro	Co, Ex, Pro
	Review (86%)...			Co, Ex, Pro	Co, Ex, Pro
	Review (2.Moment)...			Co, Ex, Pro	Co, Ex, Pro
	Caustic...			Co, Ex, Pro	Co, Ex, Pro
	Raw-beam...				
	Symmetry check...			Co, Ex, Pro	Co, Ex, Pro
	Fixed Contour Lines...			Co, Ex, Pro	Co, Ex, Pro
	Variable Contour Lines.....			Co, Ex, Pro	Co, Ex, Pro
	Graphical Review...			Co, Ex, Pro	Co, Ex, Pro
	System state...				Co, Ex, Pro
	Evaluation Parameter View...	Co, Ex, Pro	Co, Ex, Pro	Co, Ex, Pro	Co, Ex, Pro
	Color Tables...	Co, Ex, Pro	Co, Ex, Pro	Co, Ex, Pro	Co, Ex, Pro
	Toolbar	Co, Ex, Pro	Co, Ex, Pro	Co, Ex, Pro	Co, Ex, Pro
Position...		Co, Ex, Pro	Co, Ex, Pro		
Evaluation...	0	0	0	0	
Communication	Rescan bus	Co, Ex, Pro	Co, Ex, Pro	Co, Ex, Pro	Co, Ex, Pro
	Free Communication...	Co, Ex, Pro	Co, Ex, Pro	Co, Ex, Pro	Co, Ex, Pro
	Scan device list...	Co, Ex, Pro	Co, Ex, Pro	Co, Ex, Pro	Co, Ex, Pro
Script	Editor...	Op, Co, Ex, Pro	Co, Ex, Pro	Co, Ex, Pro	Co, Ex, Pro
	List...	Co, Ex, Pro	Co, Ex, Pro	Co, Ex, Pro	Co, Ex, Pro
	Python...	Op, Co, Ex, Pro	Co, Ex, Pro	Co, Ex, Pro	Co, Ex, Pro
Help	Activation...	Op, Co, Ex, Pro	Co, Ex, Pro	Co, Ex, Pro	Co, Ex, Pro
	About LaserDiagnoseSoftware...	Op, Co, Ex, Pro	Co, Ex, Pro	Co, Ex, Pro	Co, Ex, Pro

Tab.9.2: User access to software functions

9.6 Graphical user interface

In comparison with the standard version, the graphical user interface of the software is extended by an adjustment and control window and is therefore suits the requirements of an automated beam control in an industrial environment.

The additional window is divided into two halves. On the left hand side it is possible to carry out necessary settings, to start measurements or to display measurement parameters.

On the right hand side it is possible to control the measurement system or – respectively – the process parameters and to store measurement results. By means of this, you can change pre-settings and control system parameters at the same time.

The dialogue windows are clearly arranged as tabs. With one mouse click on the respective tab the dialogue window is displayed in the foreground.

Apart from the standard menus of the LDS there are menu entries which are specific for the measurement device (e.g. Environment → LQM adjustment) and which are irrelevant for the HP-MSM-I.

The dialogue window of the standard LDS always remains available via the menu bar in order to maintain the full functionality.

If you use e.g. the dialogue windows which were especially designed for the HP-MSM-I, it may occur that some functions are also available in the menu of the standard-LDS.

If you change a function in one of the two dialogue windows, this change is automatically taken over for the other one as well.

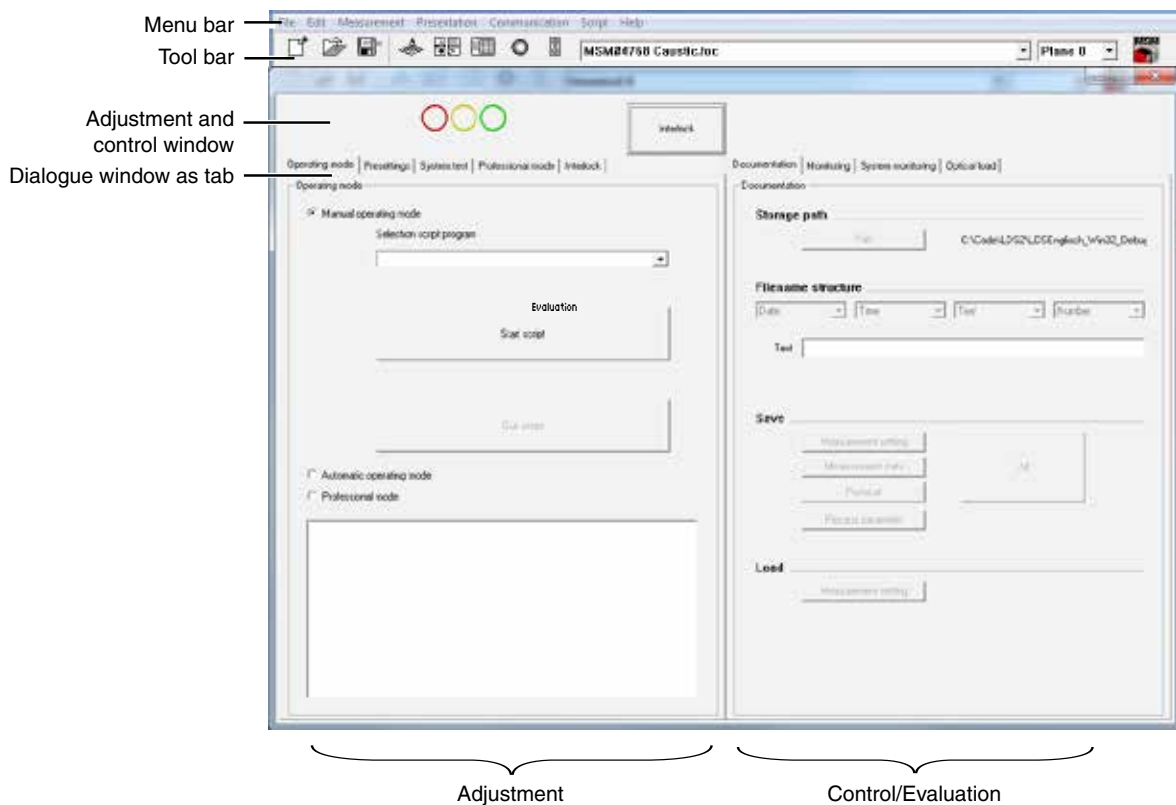

Fig.9.3: Main window of the graphical user interface

Above the two tab blogs there are two displays and one interlock button. The state of the controlled function is signalled in the dialogue windows by means of a LED symbol (green = ok; red = not ok).

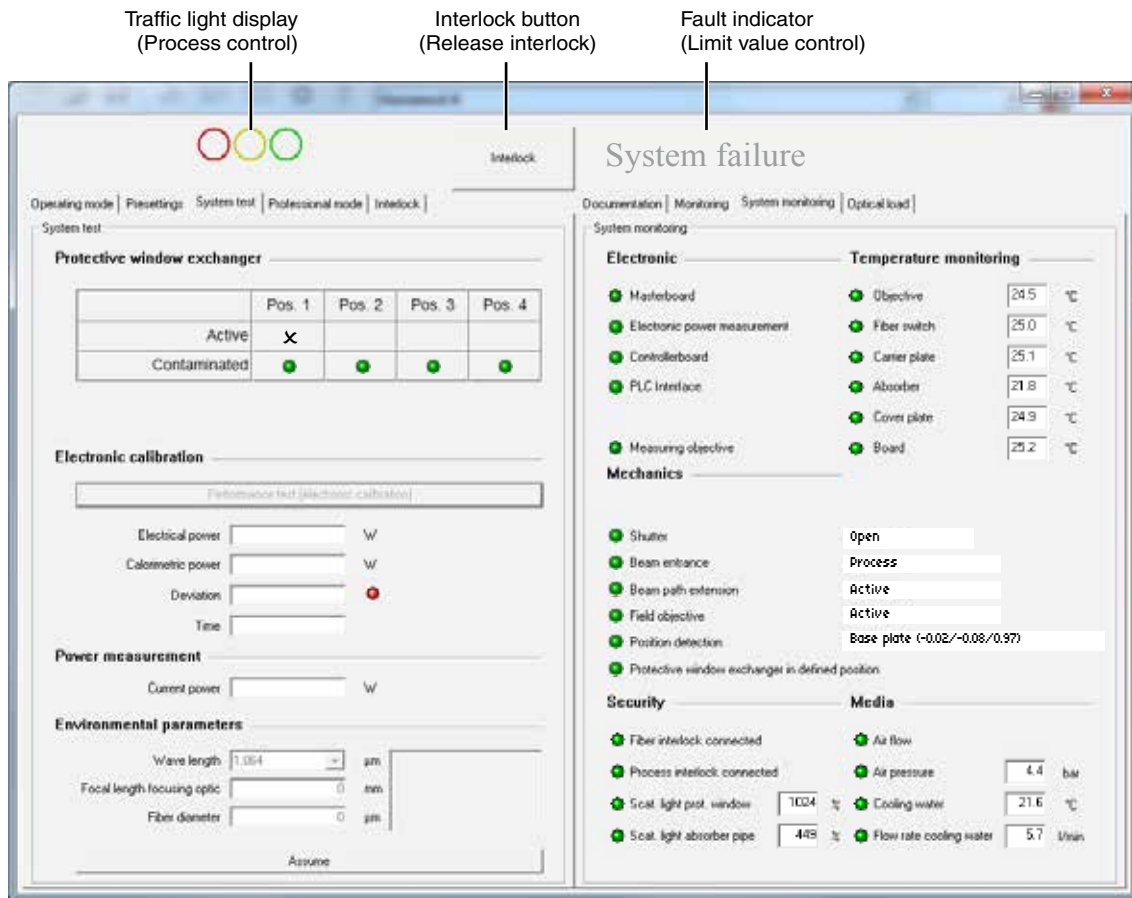

Fig.9.4: Adjustment and control window

Traffic light display process control

This is a collective display for the parameters with their limit values (e.g. laser power, focus radius, Rayleigh-length, etc.) chosen in the control function (please see chapter 9.9.7 on page 55).

Interlock

The Interlock button enables a switch off of the laser by means of the software.

Fault indicator

This indicator appears if one or several of the system parameters controlled are not within the allowed limits. A system failure is, for instance, generated if the cooling water flow rate falls below 4 l/min. The indicator of a system failure does not have any influence on the interlock. The interlock is only activated when it comes to security relevant errors.

9.7 Overview of the program functions

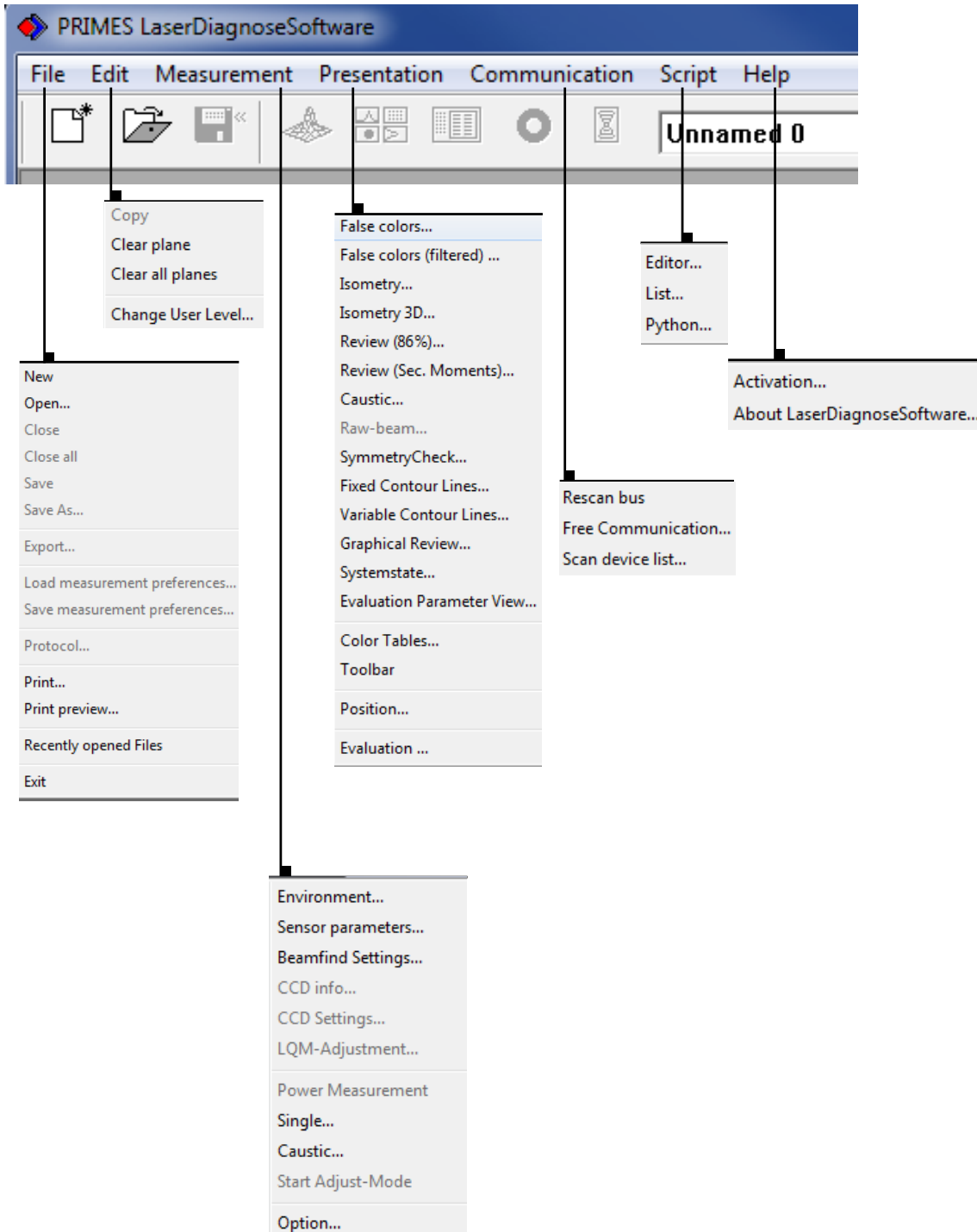

File

New	Opens a new file for the measuring data.
Open	Opens a measuring file with the extensions “.foc” or “.mdf”.
Close	Closes the file selected in the tool bar.
Close all	Closes all files opened.
Save	Saves the current file in foc- or mdf format.
Save as	Opens the menu for the storage of the files selected in the tool bar. Only files with the extensions “.foc” or “.mdf” can be imported safely
Export	Exports all current data in protocol format “.xls” and “.pk1”.
Load measurement preferences	Opens a file with measurement settings with the extension “.ptx”.
Save measurement preferences	Opens the menu to save the settings of the last program run. Only files with the extension “.ptx” can be opened.
Protocol	Starts a protocol of the numeric results. They can either be written into a file or a data base.
Print	Opens the standard print menu.
Print preview	Shows the content of the printing order.
Recently opened files	Shows the file opened before.
Exit	Terminates the program.

Edit

Copy	Copies the current window to the clipboard.
Clear plane	Deletes the data of the plane selected in the tool bar.
Clear all planes	Deletes all data of the file selected in the tool bar
Change user level...	By entering a password a different user level is activated.

Measurement

Environment	Here, different system parameters can be entered, e.g. - Reference value for the laser power - Focal length - Wave length - Remarks
Sensor parameters	The following device parameters can be e.g. set here: - The spatial resolution - The mechanical movement limits in z-direction - Selection of one of the measuring devices connected with the bus - The manual settings of the z-axis
LQM-Adjustment	Not relevant for HP-MSM-I
Beamfind settings	Not relevant for HP-MSM-I
CCD info	Informations about device parameters
CCD settings	Special settings can be adjusted here: Trigger mode trigger level Integration time Wavelength
Power measurement	Opens the measuring window power measurement.
Single...	This menu item enables the start of single measurements, of the monitor mode and the video mode.
Caustic...	Enables the start of a caustic measurement. Not only automatic measurements but also serial measurements of manually set parameters are possible. The automatic measurement starts with a beam search and then carries out the entire measuring procedure independently. Only the z-range that is to be examined as well as the desired measuring plane have to be entered.
Start adjustment mode	Not relevant for HP-MSM-I

Options Enables the setting of device parameters.

Presentation

False colors... False color display of the spatial power density distribution.

False colors (filtered)... Usage of a spatial filtration (spline-function) on the false color display of the power density distribution.

Isometry... 3-dimensional display of the spatial power density distribution.

Isometry 3D... Only active, when this special function is unlocked. Allows a 3D display of caustic and power density distribution with spatial rotation as well as an optional isophote display.

Review (86%)... Numerical overview of measuring results in the different layers basing on the 86% beam radius definition.

Review (2. Moments)... Numerical overview of the measuring results in the different layers basing on the 2nd-moment beam radius definition.

Caustic... Results of the caustic measurement and the results of the caustic fit – such as beam propagation ratio k , focus position and focus radius.

Raw beam...

Symmetry check... Analysis tool to check the beam symmetry especially for the alignment of laser resonators. No standard feature of the devices.

Fixed contour lines... Display of the spatial laser density distribution with fixed intersection lines for 6 different power levels.

Variable contour lines... Display of the spatial power density distribution with freely selectable intersection lines.

Graphical review Enables a selection of graphical displays – among them the radius, the x- and y-position above the z-position and the time.

System state Listing of the controlled system parameters.

Evaluation parameter Loading stored evaluation parameters.

Color tables... Different color charts are available in order to analyse e.g. diffraction phenomena in detail.

Tool bar In order to display or to hide the tool bar.

Position Moving the device into a defined position

Evaluation Selection of the parameters to be evaluated

Communication

Rescan bus The system searches the bus for the different device addresses. This is necessary whenever the device configuration at the PRIMES bus was changed after starting the software.

Free Communication Display of the communication on the PRIMES bus

Scan device list Not relevant for HP-MSM-I.

Script

Editor Opens the script generator, a tool, by means of which complex measuring procedures are controlled automatically (with a script language developed by PRIMES).

List Shows a list of the opened windows.

Python Opens the script generator in order to control complex measuring procedures automatically (script language Python).

Help

Activation Enables the activation of special functions

About
LaserDiagnosticSoftware Provides information regarding the software version

9.8 Basic settings for a fast CW measurement

As the PRIMES LaserDiagnosisSoftware is designed for different measurement conditions and therefore offers various setting possibilities, the main settings for a fast CW measurement are pointed out in the following (a tabular check list of these settings is provided with the device).

1. Dialogue window: Presettings

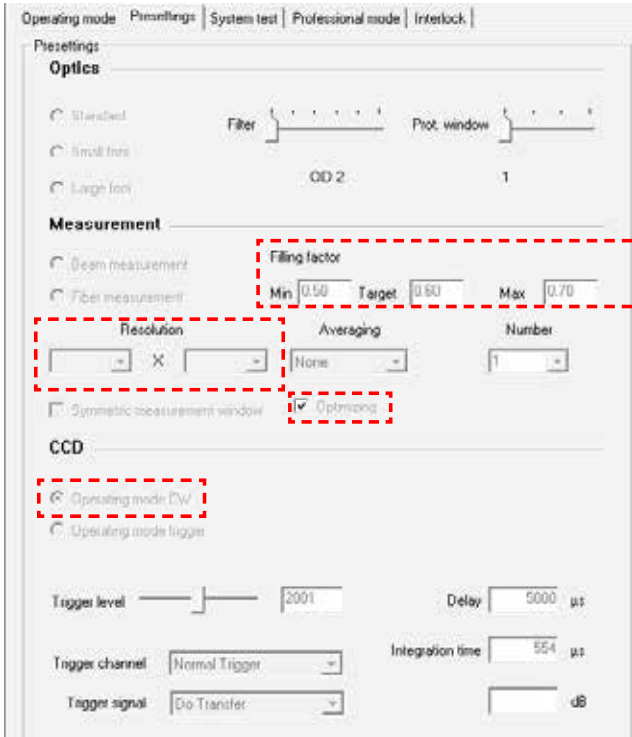

Filling factor Min 0.5 / Target 0.6 / Max 0.7

Select resolution 64 x 64

Aktiviate Optimizing

Select Operating mode CW

2. Dialogue window: System test

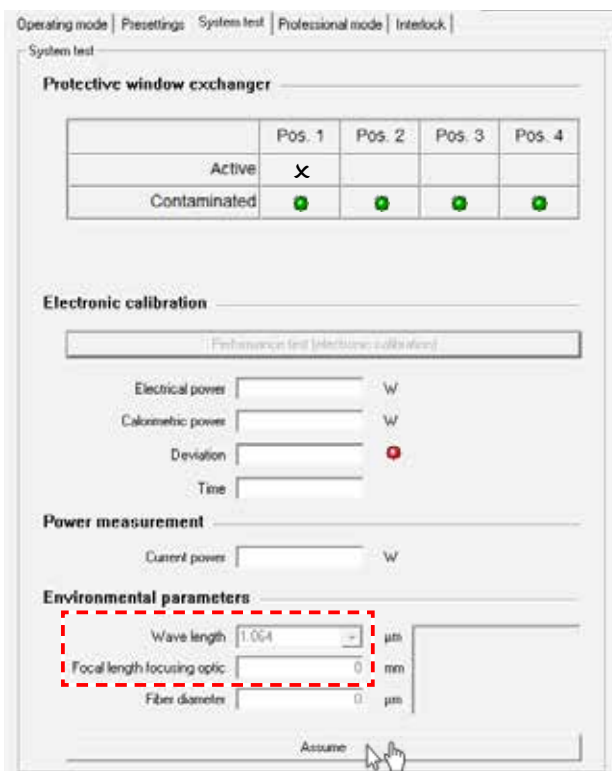

Select wavelength

Enter focal length

Assume

3. Dialogue window: Professional mode

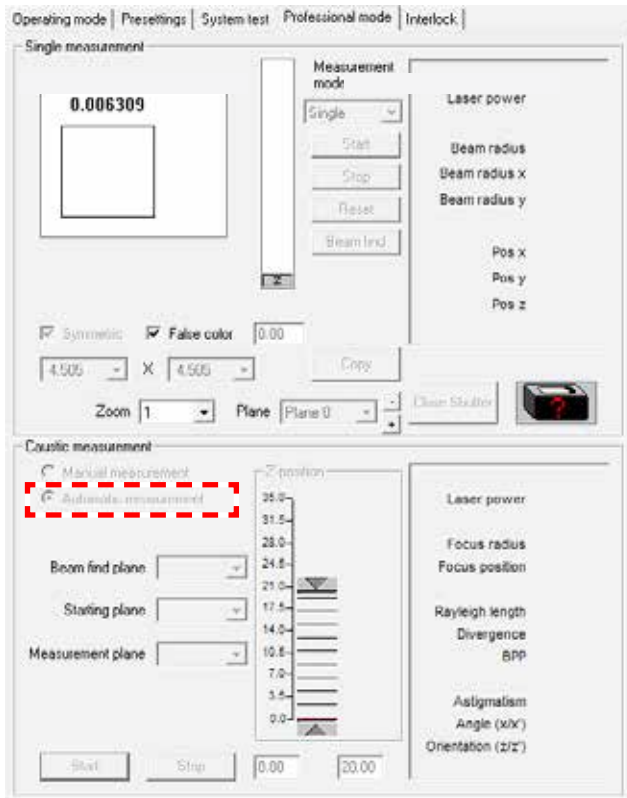

⊙ Select automatic measurement

4. Menu: Measurement → CCD Settings

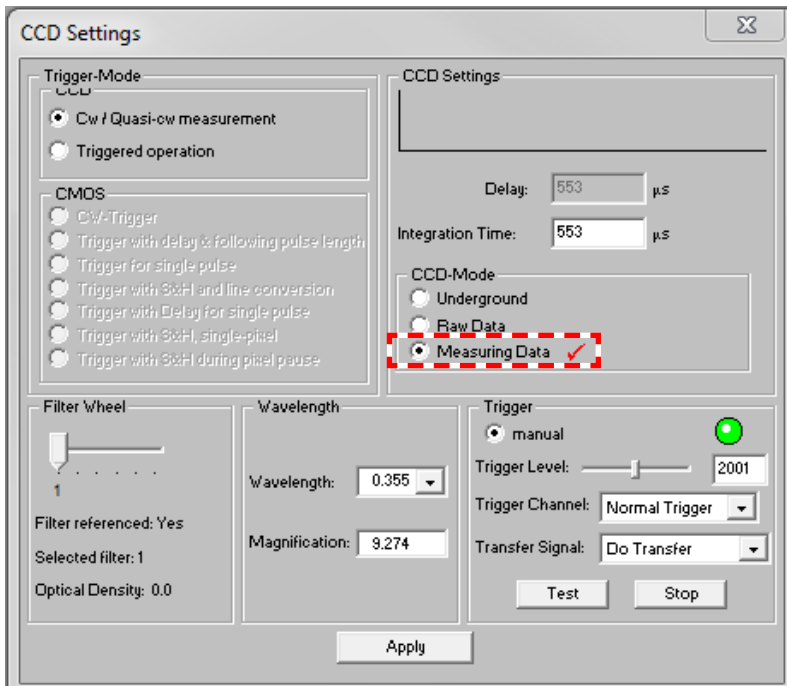

⊙ Select Measuring Data

5. Menu: Measurement → Options

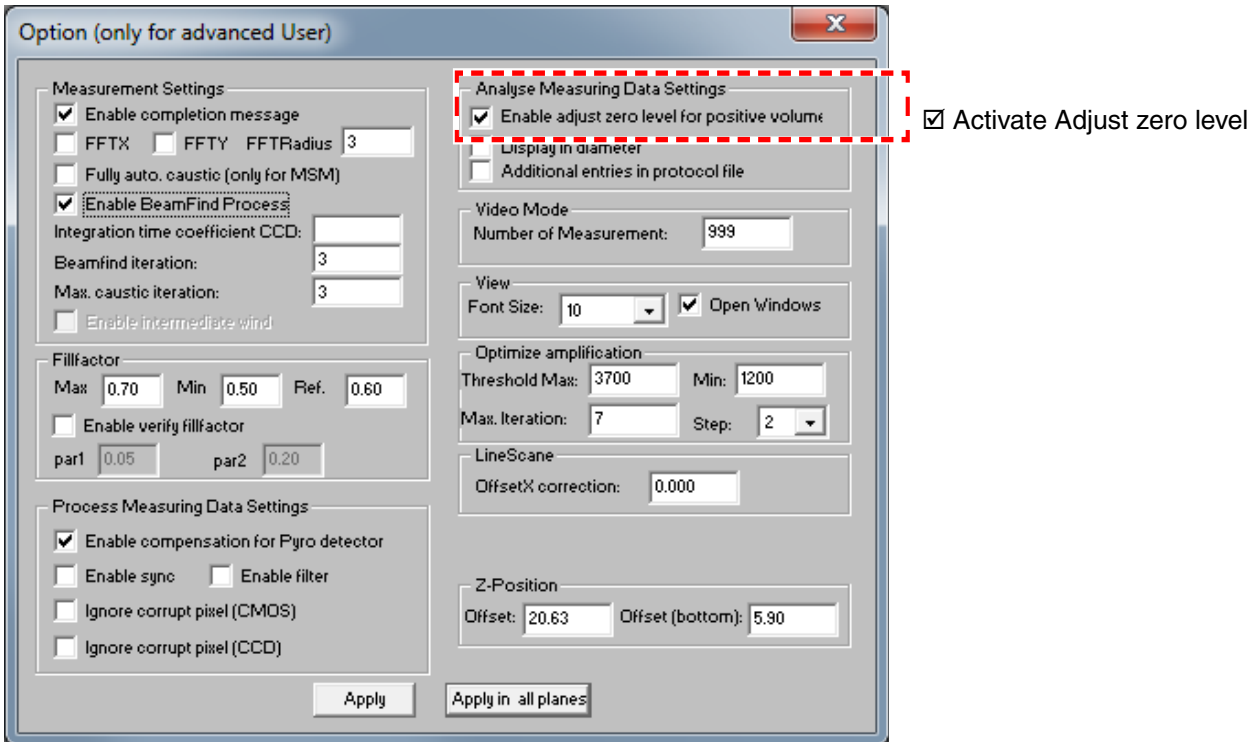

9.9 Setting possibilities in the software interface

The following remarks regarding the configuration possibilities are supposed to assist you in making suitable settings for the respective task. Three different categories are distinguished. In some figures they are emphasized by a colored frame.

Red edge

These settings always have to be effected as shown in the screen copy.

Blue edge

These settings are dependent from the desired operating mode (CW; pulse; single pulse; measurement series; etc.). Their meaning is thoroughly described in the following.

Green edge

Settings which have to be carried out before each measurement. The settings are dependent from the concrete measurement task as – for instance – the wavelength, the power or the geometry of the laser beam.

9.9.1 Operating mode

Choose the desired operating mode.

Manual operating mode

In the manual operating mode you can carry out script programs. Manual entries are not permitted. A listing of the scripts can be found in Tab.10.1 on page 79.

Automatic operating mode

The automatic operating mode is only selectable by means of the system control. In this operating mode a pre-set script is automatically carried out. The HP-MSM-I is exclusively operated via the PLC interface (please see „Automatic operating mode“ on page 95).

Professional mode

The professional mode is selectable from the user level “Professional”. All measurement functions can be operated and controlled manually. Furthermore, all standard functions of the LDS are at your disposal.

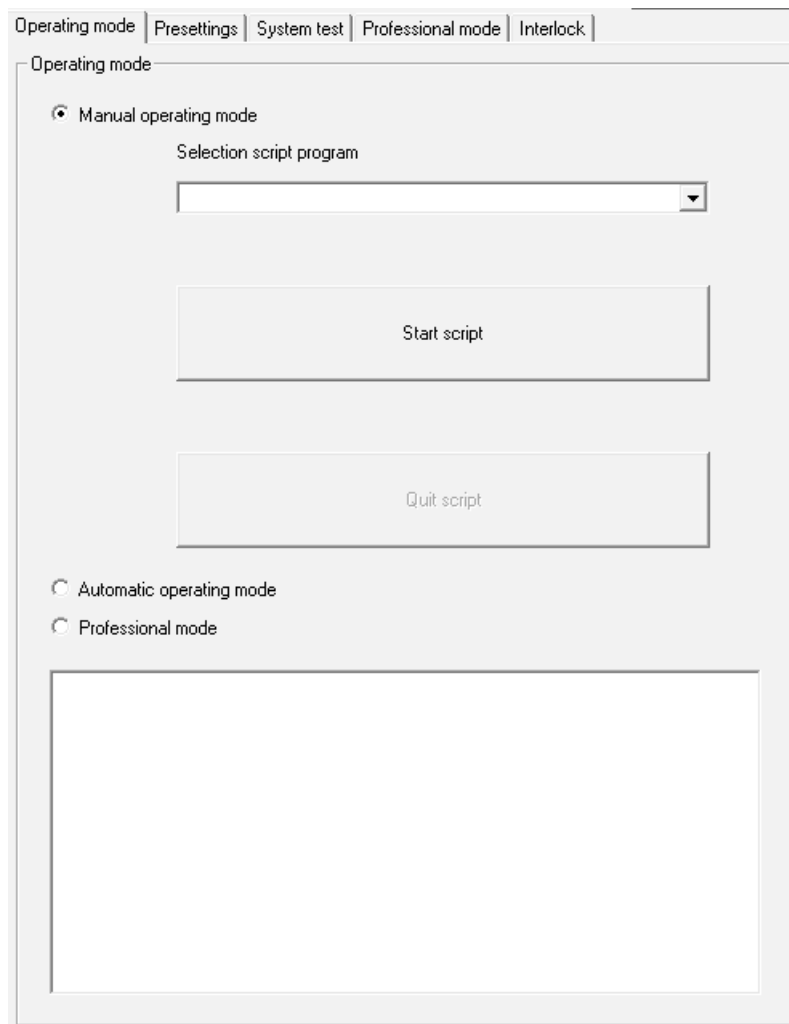

Fig.9.5: Dialogue window *Operating mode*

9.9.2 Pre-settings

In this dialogue window measurement settings for

- the optics
- the measurement
- the CCD-S

can be carried out.

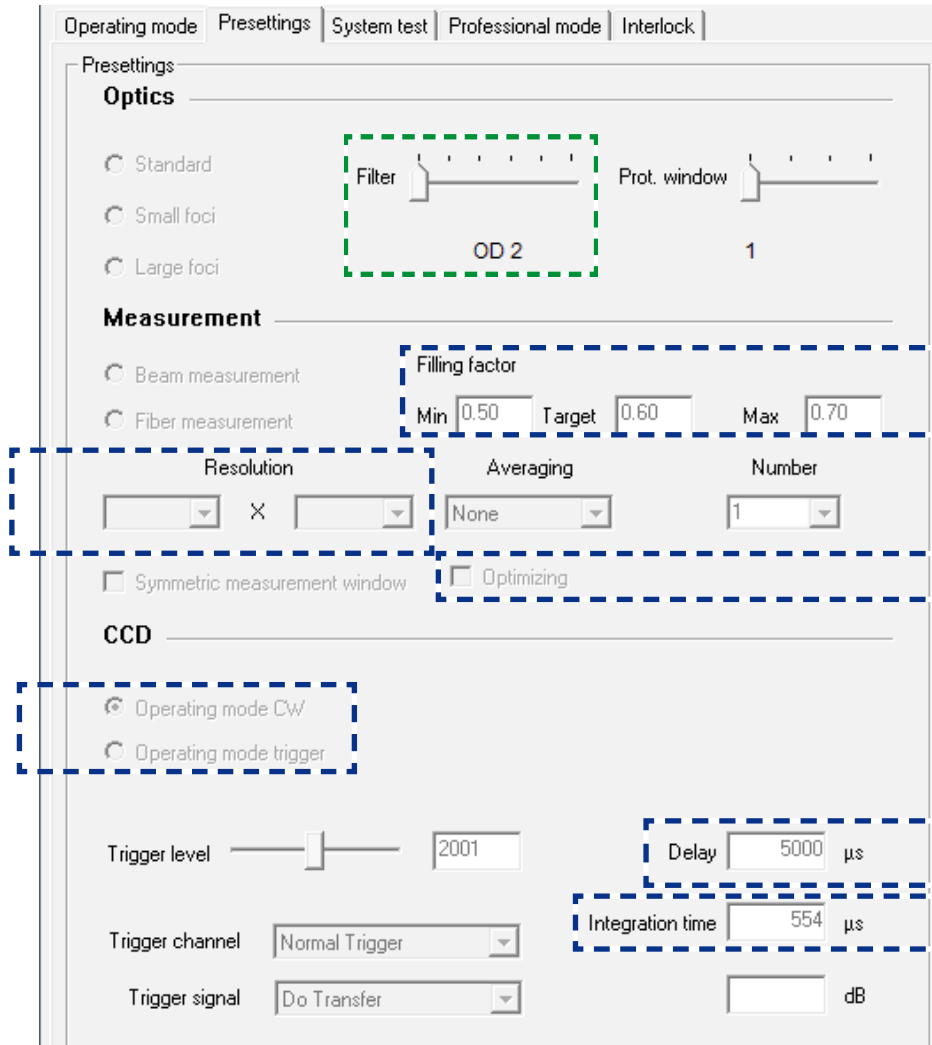

Fig.9.6: Dialogue window *Presettings*

Filter

The necessary filter is dependent on the wavelength and the intensity of the laser beam and has to be chosen in accordance with every measurement task.

The filter is suitable if all measurement planes are measured with an integration time between 18 ms (–20 dB) and 0.18 ms (–60 dB) within a caustic measurement. Outside these limits the signal-to-noise ratio of the CCD-sensor decreases which then results in a decrease of the measurement accuracy.

By default, the device is equipped with five filters with an optical density between OD1 (1:10) up to OD5 (1:100 000). Position 6 is empty, in order to let an unfiltered beam pass.

Filling factor



Standard setting: max 0.7 / min 0.5 / target 0.6.

For strongly deformed beams the value can be changed to “max 0.6 / min 0.4 / target 0.5”.

The filling factor is a quotient derived from the beam diameter as well as the edge length of the measuring window.

The filling factor has no influence on the measurement accuracy if:

- the measurement signal is not restricted
- there are no noise components in the measuring results
- there is no malfunction as far as the offset determination is concerned

As these conditions are not fulfilled in case of a real measurement, low filling factors could lead to a high measurement inaccuracy.

The optimal filling factor for the best measurement result possible is dependent on the noise- and zero level error shares of the measurement plane.

For TopHat- and Gaussian laser beams should have a filling factor between 0.5 and 0.7. In case a beam has diffraction rings which are supposed to lie within the measurement window, the optimum value for the filling factor can also be between 0.5 and 0.6.

Optimizing

Activates the automated adjustment of the integration time of the CCD for every measurement. As a result, the signal-to-noise ratio can be kept high by means of a caustic measurement. For special measurement applications it can make sense to deactivate this function and to set the integration time to a value between 12 μ s and 200 ms. With regard to this, it is important that a sufficient attenuation of the laser beam by means of the filter is ensured.

Resolution

You can indicate the number of pixels in the measurement window. Please note that a greater number of pixels leads to a longer measurement duration. Due to the measurement accuracy we recommend a resolution of 64 pixels.

Operating mode

The setting depends on the operating mode of the laser which is to be measured. Please note that the pulsed lasers with a pulse frequency which is higher than 500 Hz can also be measured in the “CW” mode. If you select a triggered operation for a CW laser system, either the error message **Error Black Pixel Measurement** or **Time out during measurement** is issued.

Delay (only for triggered operation and single pulse)

The time the measuring system is supposed to wait between the recognition of a trigger pulse and the start of a measurement. Together with the function **Exposure time** defined “windows” of pulse cycles (e.g. exactly one pulse or parts of a ms pulse) can be measured.

Exposure time

This function specifies a defined exposure time. First of all, the optimization has to be deactivated. Otherwise the exposure time is optimized and therefore changed by the device itself. This function as well is mainly used when it comes to the measurement of pulsed laser systems.

9.9.3 System test

In the dialogue window System parameter you can check the condition of the protective windows, start an electronic calibration and enter ambient parameters.

Protective window exchanger

The protective window which is located in the entrance aperture is marked with a cross. A contamination of the protective window is signaled by means of a red LED.

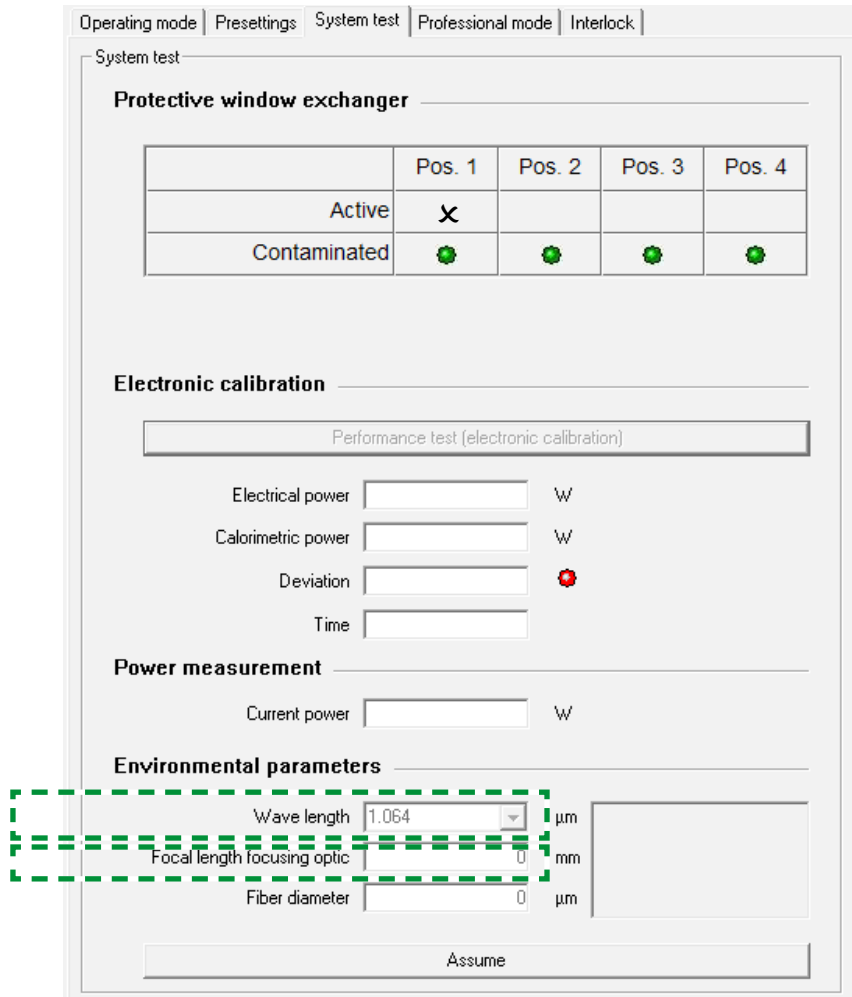

Fig.9.7: Dialogue window *System test*

Wavelength

The total magnification of camera-based systems is dependent on the wavelength. Therefore, it has to be ensured before each measurement that the right choice was made. The wavelengths showed here are calibration points of the measuring objective. Due to the achromatic characteristics of the measuring objectives you can, for instance, measure in a wavelength range between 1030 nm and 1100 nm with the calibration point at 1064 nm, without causing significant measurement errors.

Focal length

By means of the value entered a back calculation to the raw beam diameter is carried out in the display window *Caustic*. For measurement systems of the MSM series the value has to be entered manually.

9.9.4 Professional mode

Single measurements as well as caustic measurements can be carried out. The functionality equals the two measurement windows *Single measurement* and *Caustic measurement* in the LDS standard software.

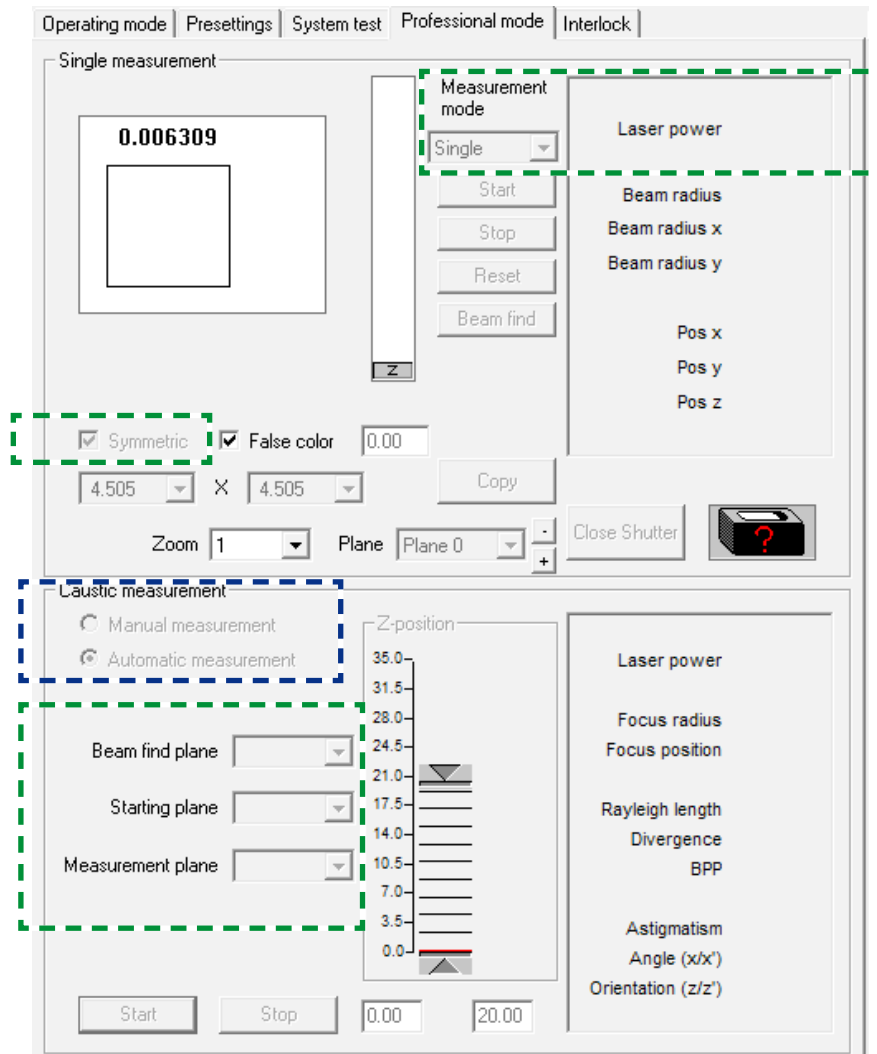

Fig.9.8: Dialogue window *Professional mode*

Measurement mode

You can choose three measurement modes. As far as *Single measurement* and *Monitor operation* are concerned, all necessary compensations (smear, diffusion) and the integration time adjustment is carried out again for each measurement.

This means that valid measuring data are generated in these modes.

The operating mode *Video mode* generates defective measuring data. Here, the integration time of the last measurement is taken over and not varied. Moreover, no compensation measurement is carried out which means that interfering signals are not inhibited.

Due to the "high" frequency of approx. 5 Hz it can, however, still make sense to work with this operating mode. The numerical results are, however, only conditionally reliable and should not be evaluated in absolute terms but relatively to each other.

Symmetric

When it comes to this option only quadratic measuring windows are permitted. Please deactivate this option if you want to measure an elliptic or rectangular laser beam.

Caustic measurement

Concerning the automated measurement, the measurement system and the LDS determine the ideal measuring window position (in x- and y-direction) for each measurement plane and the optimal measurement window size for the filling factor.

With the number of measurement planes and the measurement limits in z direction the plane position in z direction is determined.

When it comes to the adjustment of the measuring window size as well as the measuring window position in x- and y-direction the number of iterations (at least three per plane) can lead to an extended measurement duration.

In case of recurring measurement tasks and repeated measurements please choose the measuring mode **Manual measurement**. Then the measuring system takes over the measuring window position as well as the measuring window size of the last measurement or it uses the settings from a .ptx-file (please see chapter 9.9.6 on page 54). This considerably reduces the measurement duration. However, this implies that the position and the parameters of the laser beam only change slightly.

Beam find plane

In this dropdown-field you indicate the plane in which the beam is searched. If the function **BeamFind** is activated in the dialogue window **Options**, this is also the plane in which this function is carried out. In case of a deactivated **BeamFind** function, this plane has to be pre-measured manually in order to ensure that the laser beam is found.

Starting plane

In the dropdown field **Starting plane** you can state the plane number in which the measurement is started (factory setting plane 0). Please only change the factory setting if you measure in an existing document and if you do not want to overwrite the existing measurement data.

If you have measured a caustic with 21 planes, for instance, and would like to extend the measurement range to smaller z values, you can set the starting plane on 21 and change the measurement range accordingly. The new measurement values will then be written into the existing document, starting from plane 21.

Measurement planes

In the dropdown field **Measurement planes** you can stipulate the number of planes which are to be measured in the z-range. Due to the fact that the program always sets the measurement plane distances equidistantly in the automatic operating mode and the measurement range almost always lies symmetrically around the focus you should choose an odd number of measurement planes. This ensures that the focus plane is measured.

The beam measurement standard DIN 11146 stipulates at least 10 measurement planes. Five measurements are supposed to be measured within one Rayleigh length and five measurements beyond two Rayleigh lengths. With an equidistant distribution this results in at least 17 measurement planes in a range of ± 3 Rayleigh lengths.

9.9.5 Interlock

The dialogue window interlock enables a shutdown of the lasers by means of the software. With the button **Trigger interlock** you turn off the laser. With the button **Reset interlock**, the safety circuit is released again.



Fig.9.9: Dialogue window **Interlock**

9.9.6 Documentation

Here you can define which data are stored in which directory and under which name. Settings which are already stored can be loaded as current settings by means of the button **Measurement settings** in the window section **Load**.



Fig.9.10: Dialogue window **Documentation**

Storage path

Please click the button **Path** in order to choose the desired storage location.

Structure file name

Here you can stipulate the structure of the desired file name. You are free to choose the order of the structural elements date, time, text and serial number. In the input field **Text** you can enter an arbitrary file name. The structural elements are separated by means of an underscore.

Example:

20_01_2012_17_05_testmeasurement_001.fileextension



Storage

You can either store the different data sets separately or all of them simultaneously. The files receive the following file extensions:

Measurement setting	.ptx
Measurement data	.foc
Protocol	.txt
Process parameter	.eval

9.9.7 Evaluation

In this dialogue window you choose the parameters which are to be controlled and stipulate the limit values. The measurement results are displayed (actual) and compared with the limit values. With the buttons underneath the table you can store the settings or reload stored settings.

	Min	Warn	Actual	Warn	Max
<input checked="" type="checkbox"/> Standard Fit [%]	0.00	0.50	3.48	3.00	5.00
<input checked="" type="checkbox"/> Power Stable [W]	-100	-50	0	50	100
<input checked="" type="checkbox"/> Astigmatism Ratio [%]	0.00	0.00	0.03	0.50	1.00
<input checked="" type="checkbox"/> Focus Radius X [mm]	0.0100	0.0300	0.0333	0.0500	0.1000
<input checked="" type="checkbox"/> Focus Radius Y [mm]	0.0100	0.0300	0.0320	0.0500	0.1000
<input checked="" type="checkbox"/> Focus Radius [mm]	0.0100	0.0300	0.0386	0.0500	0.1000
<input checked="" type="checkbox"/> Focus Position X [mm]	-0.200	-0.100	0.021	0.100	0.200
<input checked="" type="checkbox"/> Focus Position Y [mm]	-0.200	-0.100	0.040	0.100	0.200
<input checked="" type="checkbox"/> Focus Position Z [mm]	80.000	82.000	82.332	85.000	90.000
<input checked="" type="checkbox"/> KValue	0.50	0.67	0.64	1.00	1.00
<input checked="" type="checkbox"/> KValue X	0.50	0.67	0.86	1.00	1.00
<input checked="" type="checkbox"/> KValue Y	0.50	0.67	0.90	1.00	1.00
<input checked="" type="checkbox"/> Caustic Min Power [W]	50	100	0	10000	10000
<input checked="" type="checkbox"/> Caustic Max Power [W]	0	0	0	7500	8000
<input checked="" type="checkbox"/> Caustic Mean Power [W]	0	50	0	7500	8000
<input checked="" type="checkbox"/> BPP	0.200	0.250	0.532	0.750	1.000
<input checked="" type="checkbox"/> M ²	1.00	1.00	1.57	1.50	2.00
<input checked="" type="checkbox"/> M ² X	1.00	1.00	1.57	1.50	2.00
<input checked="" type="checkbox"/> M ² Y	1.00	1.00	1.57	1.50	2.00
<input checked="" type="checkbox"/> BeamDirection [°]	0.00	0.00	0.36	2.00	3.00
<input checked="" type="checkbox"/> BeamDirection X [°]	0.00	0.00	0.36	2.00	3.00
<input checked="" type="checkbox"/> BeamDirection Y [°]	0.00	0.00	0.36	2.00	3.00
<input checked="" type="checkbox"/> Rayleigh Length [mm]	0.01	0.03	2.80	10.00	30.00
<input checked="" type="checkbox"/> Divergence [mrad]	0.05	0.10	10.00	0.35	0.40

Fig.9.11: Dialogue window *Evaluation*

If the limit values are exceeded, this has an influence on the color depiction in the traffic light display (please see Fig.9.4 on page 40). As soon as a warning value exceeds or falls below the limit, the yellow circle starts glowing. If the min / max values are exceeded or fallen below, the red circle starts glowing. The actual values in the table of the control window are marked in colors as well.

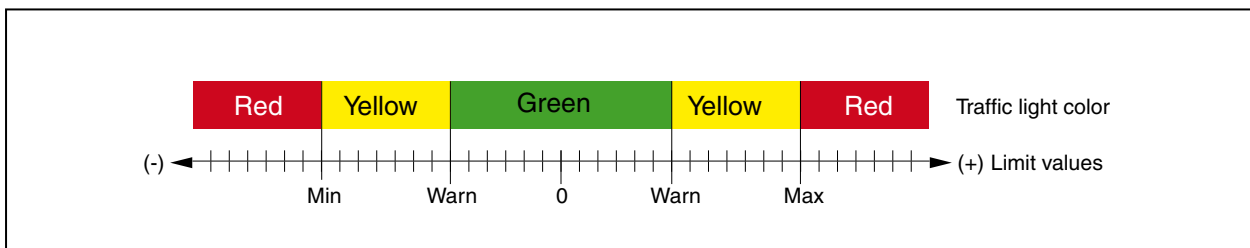

Fig.9.12: Traffic light colors when exceeding the limit values

9.9.8 System monitoring

In the dialogue window of the system monitoring the controlled system parameters and sensor information are displayed.

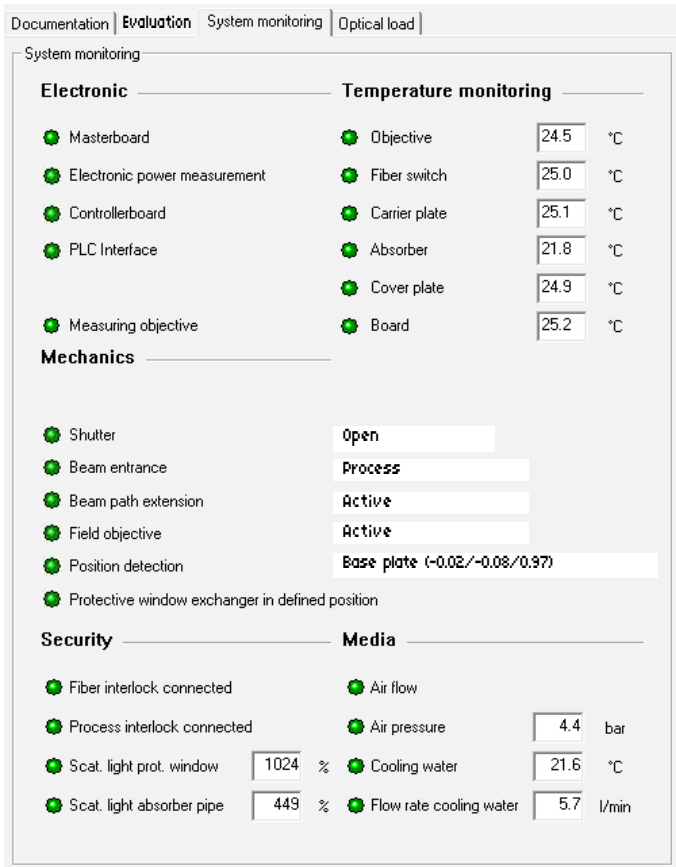

Fig.9.13: Dialogue window *System monitoring*

Localization

The position is detected by a triaxial acceleration sensor. The gravitational force vector serves as a reference. The display depends on the device position. When mounted, the localization would display the values 0/0/1g (x/y/z) via the bottom plate if aligned accurately (tolerance ± 0.1g).

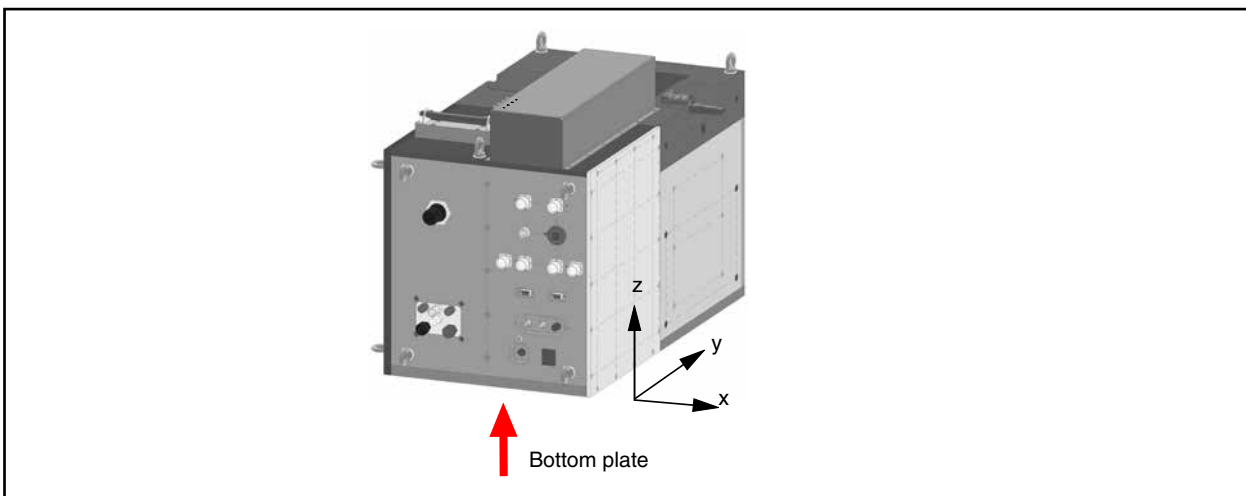

Fig.9.14: Coordinates of the localization

Scattered light protective window / absorber pipe

The display can depict 0 ... 4095 counts (12 bit). This control is interlock relevant. As there are currently no practice-oriented experience values, the limit value is set correspondingly high.

Temperature control

An alert- and interlock threshold is defined for the temperature control. If the alert threshold is reached, the LED symbol starts glowing in red (🔴). When reaching the interlock threshold, the interlock is activated.

Controlled position	Alert threshold in °C	Interlock threshold in °C
Objective	40	55
Fiber switch (deflecting mirror)	70	80
Carrier plate of the focus measuring system	40	55
Absorber		
Cover plate (entrance block)		
Boards		

Tab.9.3: Alert- and interlock threshold

9.9.9 Optical load

After a caustic measurement an evaluation regarding the maximum permissible laser power is carried out in this dialogue window. Especially in case of “unknown” laser beam parameters this dialogue is supposed to help protecting the measuring system from damages.

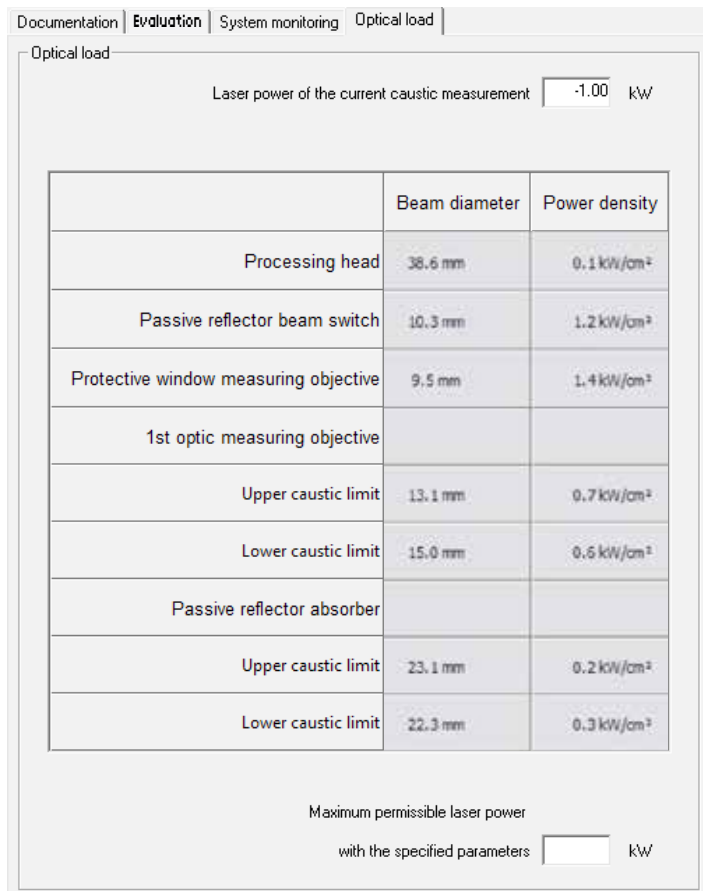

Fig.9.15: Information on the optical load

9.9.10 Dialogue window *Option* (Standard menu *Measurement*)

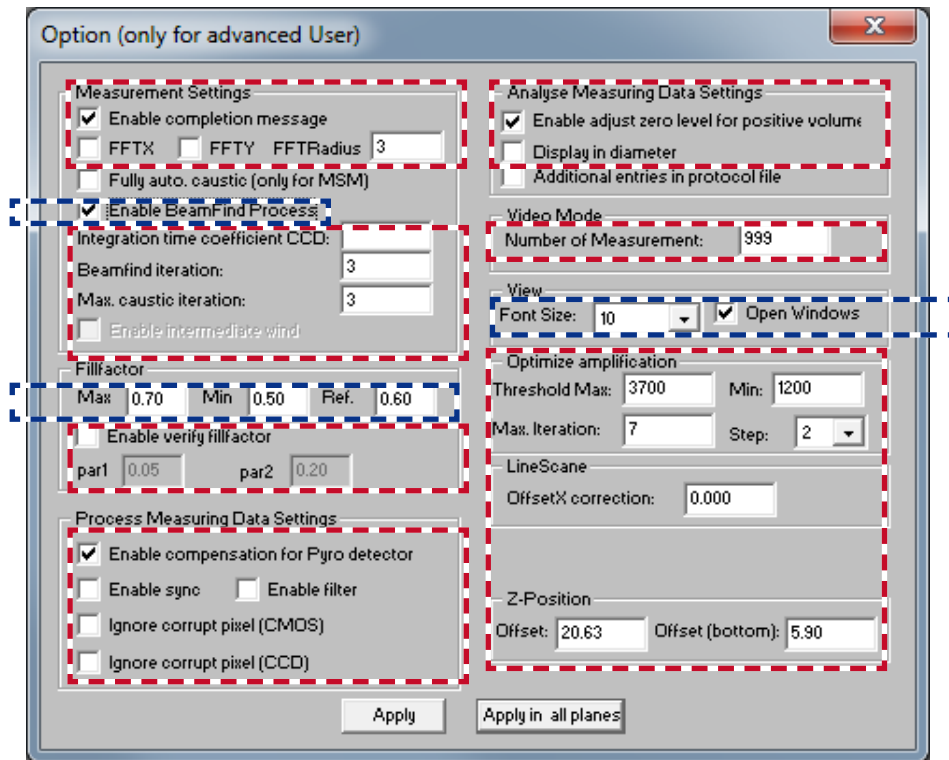

Fig.9.16: Dialogue window *Option*

Activating BeamFind



By default, this function should be activated and it should only be deactivated by experienced users.

This function is needed for caustic measurements. It is an algorithm which divides the measurement signal from the interference signal (e.g. noise) via an adjustable trigger threshold and which attunes the size of the measuring window to this signal. This algorithm is only carried out in the BeamFind plane (dialogue window *Caustic*). In all other measurement planes the measuring window size is only determined by means of the filling factor.

If you deactivate this function, you have to “pre-measure” the BeamFind plane manually. Otherwise it might occur that the measuring window is positioned on the edge of the measurement range so that no measuring signal lies within it. A useful measurement is not possible anymore then.

If the BeamFind function is deactivated you can save around 20 seconds of measuring time per caustic measurement.

Filling factor (please see page 58)

Font size

The font size in the dialogue windows. Factory setting is 10 pt.

Opening windows

If this option is activated, some basic windows are automatically opened when starting the software.

Dialog window *CCD Settings* (Standard menu *Measurement*)

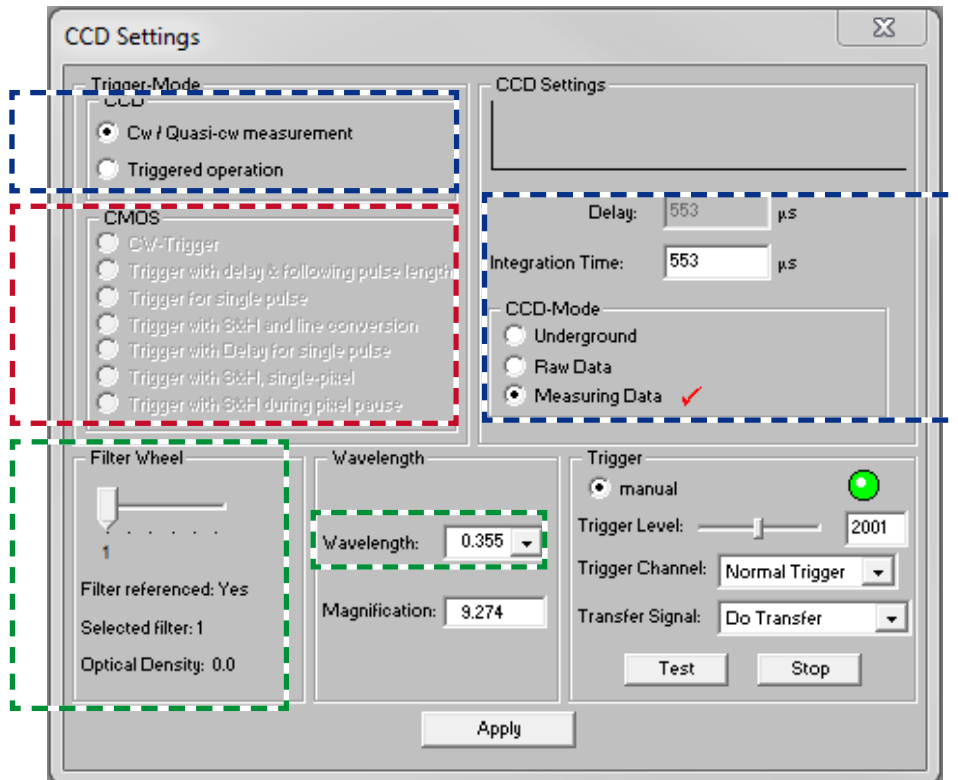

Fig.9.17: Dialogue window *CCD Settings*

The settings are identical with the dialogue window described in chapter „9.9.2 Pre-settings“ on page 48.

9.9.11 Dialogue window *Sensor parameters* (Standard menu *Measurement*)

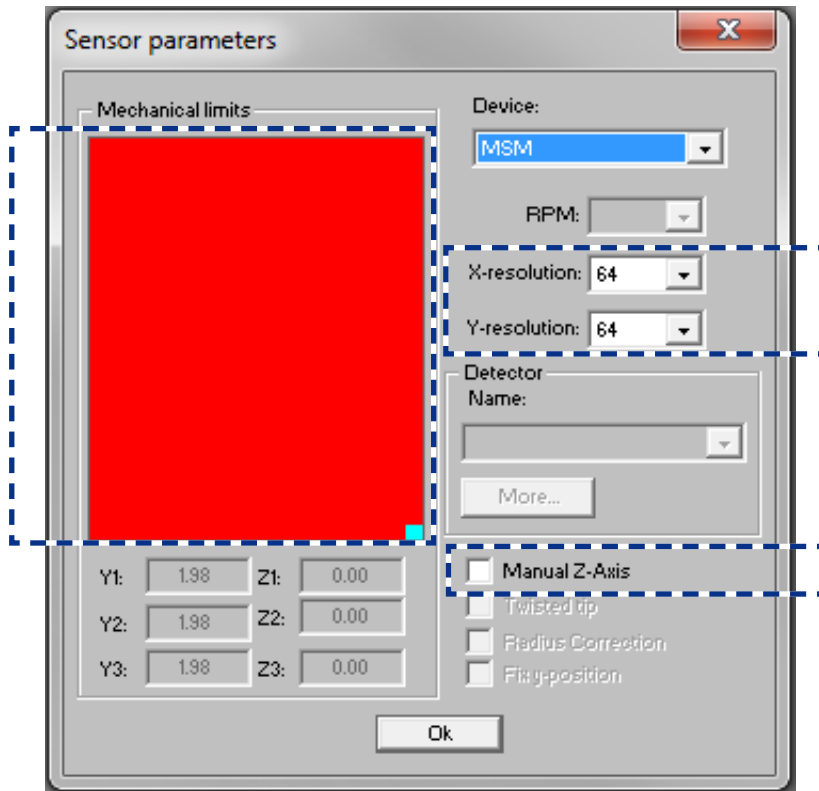

Fig.9.18: Dialogue window *Sensor parameters*

Restriction area (for the HP-MSM-I not relevant)

By pulling the turquoise square with the mouse pointer you can restrict the movement range of the y- and z-axis. Therewith you can prevent damages in case other components reach into the movement range of your measuring system.

Resolution

Here you can stipulate the number of pixels in the measuring window. Please note that a larger number of pixels results in longer measurement duration. Due to the measurement accuracy we recommend at least one resolution of 64 pixels (the measuring window size depends on the resolution of your monitor).

Manual z-axis

With this function you can deactivate the z-axes of the measuring system. This is useful if you want to use external movement axes. In this case you can manually assign a z-value to every measurement plane in the dialogue window *Single measurement*

9.9.12 Dialogue window *Measuring Environment*

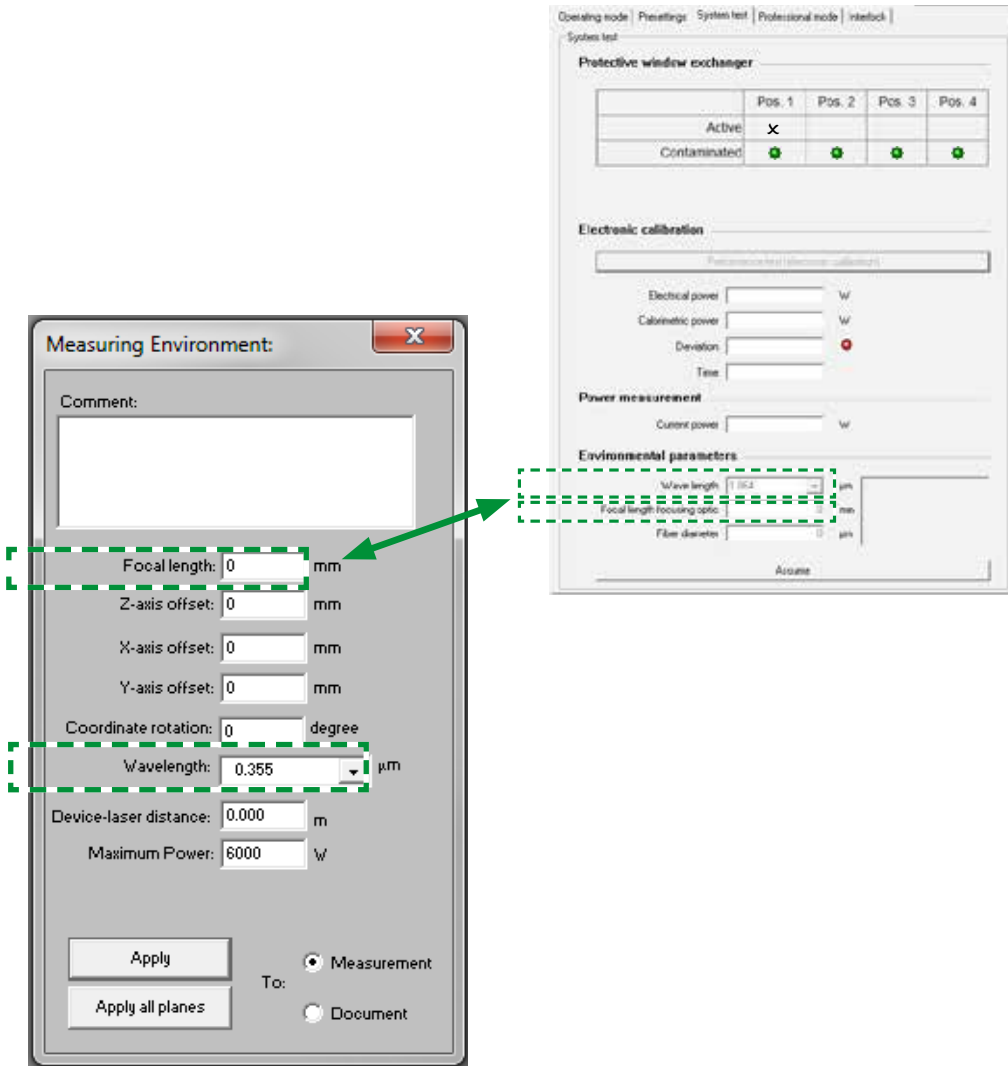

Fig.9.19: Dialogue window *Measuring Environment*

The settings are identical to the dialogue window described in chapter „9.9.3 System test“ on page 50.

9.9.13 Dialogue window *Measurement settings*

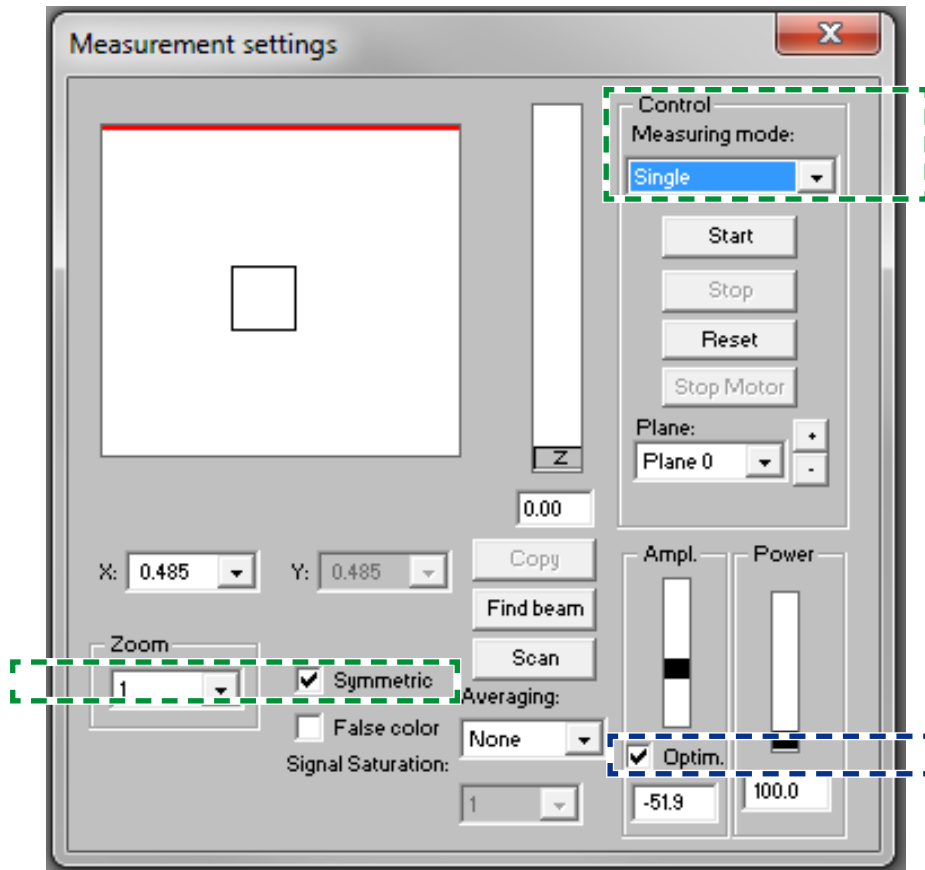

Fig.9.20: Dialogue window *Measurement settings*

The settings are identical to the dialogue window described in chapter „9.9.4 Professional mode“ on page 51.

9.9.14 Dialogue window *Caustic settings*

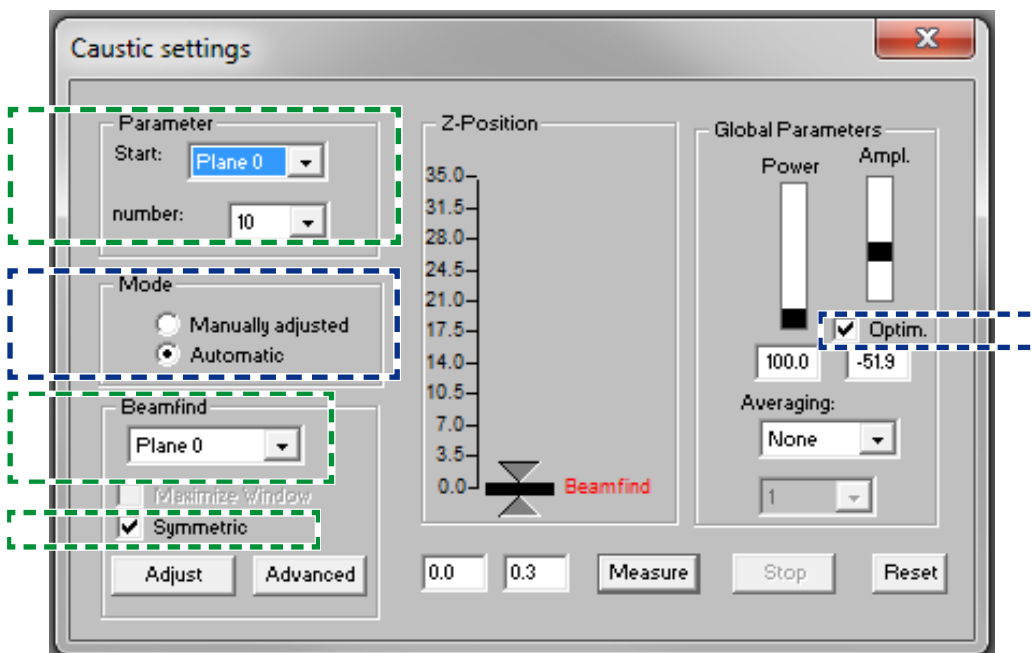

Fig.9.21: Dialogue window *Caustic settings*

The settings are identical to the dialogue window described in chapter „9.9.4 Professional mode“ on page 51.

9.10 Presentation and documentation of the measuring results

This chapter describes the presentation, analysis and storage of measuring results.

The toolbar

In order to carry out comparisons between different measurements, the program can manage several measuring data sets simultaneously. The opened data sets are shown in the tool bar. In order to open one depiction, the data which is to be examined is selected in the list of the data selection and afterwards the desired kind of presentation is chosen.

By clicking the symbols of the tool bar the following software menus are directly available.

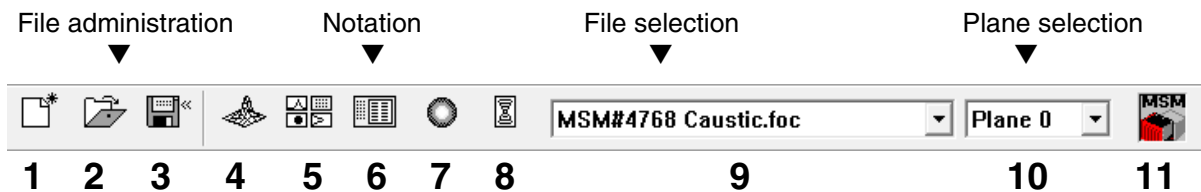

- 1 - Create a new data record
- 2 - Open an existing data record
- 3 - Save the current data record
- 4 - Open the isometric view of the selected data record
- 5 - Open the variable contours line view
- 6 - Open review (86%)
- 7 - Open false color depiction
- 8 - Caustic presentation 2D
- 9 - List with all data records opened
- 10 - Display of the selected measuring plane
- 11 - Display of the measuring devices available for the bus by means of graphical symbols

All measuring results are always written into the document selected in the toolbar. It is only possible to display documents chosen here. After opening, the data set has to be explicitly selected.

In the menus for the notation of single measurements (*variable contour lines, isometry and false color depiction*) the option **Automscale** effects the usage of the entire display range for the measuring values. In the three menus for the display of the single measurement: Free intersection lines, isometry and false color depiction the button Autom. scaling causes a usage of the total display spectrum for the measuring values.

The title of the dialogue window indicates the name of the data sets shown. By means of *planes* it is also possible to switch back and forth between different image memories of the measurement series – switching is possible with the cursor buttons up/down if the plane selection is selected. If the plane selection in the display menu is set to *global* a simultaneous switching between the planes is possible by means of the selection in the toolbar. The title of the display window indicates the name of the depicted data set.

9.10.1 False colors

Here, a false color depiction of the measured power density distribution is generated.

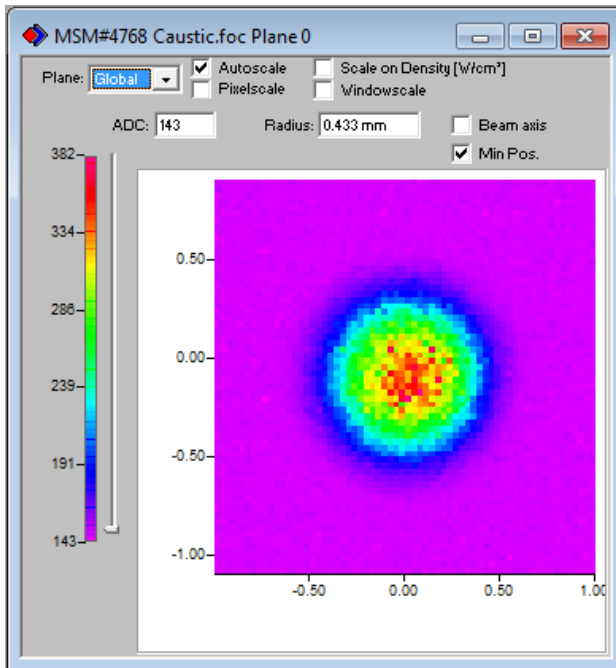

Fig.9.22: Dialogue window *False colors*

The color scale used is displayed on the left. For an increased sensitivity, for instance for the analysis of diffraction figures, you can switch the color scale used in the menu *Color tables*.

Apart from the automated scaling there are three further types of scaling

Scale on density

All planes of a caustic measurement are scaled to the maximum measured power density. By means of this the single planes can be compared more easily.

Pixelscale

The scaling is only interesting in case of the usage of asymmetric measuring windows. The windows are then no longer a function of the measuring window size but of the number of pixels measured.

Windowscale

With regard to this window all measuring windows of a caustic measurement are extended to the size of the maximum measurement window. This function shall help comparing the single measurement planes of a caustic measurement more easily.

9.10.2 False colors (filtered)

The function that is at the basis of the filter is a spline function. It is characterized by the fact that the position of the maxima are maintained. With regard to this the single pixels in a matrix are weighted with a 1-2-1 filter so that the noise is reduced.

This filter can be used several times without the position of the maxima being moved.

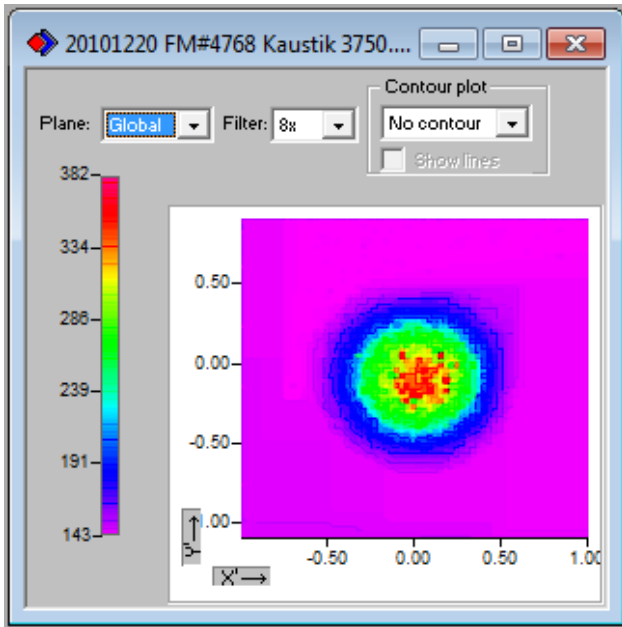

Fig.9.23: Dialogue window *False colors (filtered)*

9.10.3 Isometry 3D

This menu point generates a spatial depiction of the measured power density distribution of a plane. The color display can be deactivated.

A rotation of the distribution by 0°, 90°, 180° and 270° each is possible.

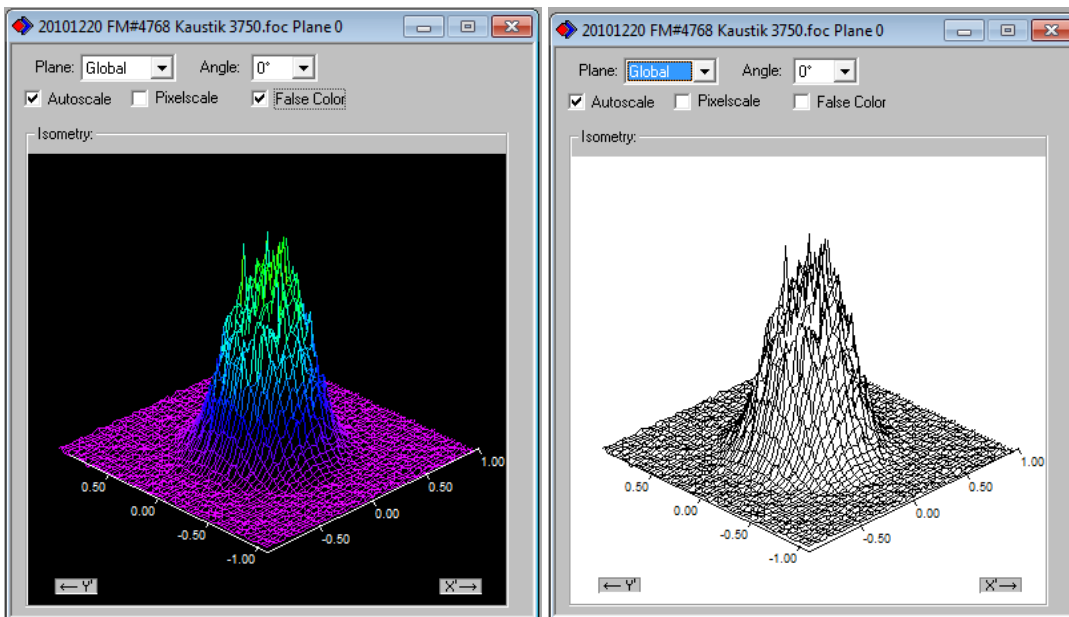

Fig.9.24: Dialogue window *Isometry 3D>>Display* (on the left with a deactivated color display)

9.10.4 Review 86 % -respectively- 2nd Moment

The following parameters are displayed: Date of the measurement, time of the measurement as well as the entries of the menu item **measurement environment**. The focal length, the offsets and the content of the comment field.

Plane:	Plane 0	Plane 1	Plane 2	Plane 3	Plane 4	Plane 5
Radius [mm]	0.433	0.398	0.354	0.313	0.269	0.234
Position X [mm]	-0.010	-0.023	0.006	0.002	0.005	0.010
Position Y [mm]	-0.108	-0.109	-0.098	-0.102	-0.100	-0.104
Position Z [mm]	75.000	75.500	76.000	76.500	77.000	77.500
Zero level [A/D-Cnts]	149.750	149.500	149.250	149.250	149.750	149.750
Power [kW]	0.900	0.900	0.900	0.900	0.900	0.900
Radius inten. [kW/cm ²]	46.196	51.489	64.628	82.461	119.463	155.745
Peak inten. [kW/cm ²]	280.498	435.540	547.987	586.358	769.836	1077.156
Date:	20.12.2010	20.12.2010	20.12.2010	20.12.2010	20.12.2010	20.12.2010
Time:	14:54:26	14:54:34	14:54:48	14:54:56	14:55:10	14:55:18
Focal length [mm]	200.000	200.000	200.000	200.000	200.000	200.000
Z-axis-offset	0.000	0.000	0.000	0.000	0.000	0.000
X-axis-offset	0.000	0.000	0.000	0.000	0.000	0.000
Y-axis-offset	0.000	0.000	0.000	0.000	0.000	0.000
Coord.rotation [deg.]	0.000	0.000	0.000	0.000	0.000	0.000
Wavelength [µm]	1.064	1.064	1.064	1.064	1.064	1.064
Fill Factor	0.433	0.398	0.472	0.418	0.538	0.468
Comment:						

Fig.9.25: The menu item **Review 86 %** in the menu **Presentation**

Moreover, the following numerical results of the measurement are displayed.

- Beam radius
- x-beam radius (only in case of 2nd moment of the big main axis)
- y-beam radius (only in case of 2nd moment of the small main axis)
- x-position
- y-position and possibly z-position
- power density (with regard to the power value set in the measurement menu).

The main difference between the two overview menus is that on the one hand the beam radii are determined according to an 86 % power definition and on the other hand the 2nd moment method according to ISO 11146 is used.

If the measurement signal slightly exceeds the zero level, the measurement results are not shown in black but in grey. In this case it should be checked carefully if this measurement values have to be discarded and if the measurement possibly has to be repeated with different settings.

The entries power, focal length as well as wavelength, especially in the comment lines can be changed after a measurement. Therefore, the **Update** function in the menu item **Environment** is available.



The comments must not contain the symbol '#'. The symbol would result in serious problems when it comes to the storage or loading of measurement files.

20101220 FM#4768 Kaustik 3750.foc- 2. Moments Review						
Plane:	Plane 0	Plane 1	Plane 2	Plane 3	Plane 4	Plane 5
Radius [mm]	0.451	0.430	0.368	0.332	0.272	0.237
Radius X [mm]	0.449	0.428	0.369	0.331	0.273	0.237
Radius Y [mm]	0.453	0.432	0.367	0.332	0.272	0.238
Angle [°] (x/y-plane)	-20.8	10.1	33.5	17.1	37.2	26.2
Position X [mm]	-0.006	-0.020	0.006	0.001	0.003	0.008
Position Y [mm]	-0.103	-0.113	-0.098	-0.104	-0.104	-0.105
Position Z [mm]	75.000	75.500	76.000	76.500	77.000	77.500
Zero level [A/D-Cnts]	149.750	149.500	149.250	149.250	149.750	149.750
Power [kW]	0.900	0.900	0.900	0.900	0.900	0.900
Peak inten. [kW/cm²]	280.498	435.540	547.987	586.358	769.836	1077.156
Date:	20.12.2010	20.12.2010	20.12.2010	20.12.2010	20.12.2010	20.12.2010
Time:	14:54:26	14:54:34	14:54:48	14:54:56	14:55:10	14:55:18
Focal length [mm]	200.000	200.000	200.000	200.000	200.000	200.000
Z-axis-offset	0.000	0.000	0.000	0.000	0.000	0.000
X-axis-offset	0.000	0.000	0.000	0.000	0.000	0.000
Y-axis-offset	0.000	0.000	0.000	0.000	0.000	0.000
Coord.rotation [deg.]	0.000	0.000	0.000	0.000	0.000	0.000
Wavelength [µm]	1.064	1.064	1.064	1.064	1.064	1.064
Radius X' [mm]	0.449	0.429	0.369	0.331	0.272	0.237
Radius Y' [mm]	0.452	0.432	0.368	0.332	0.272	0.237
Fill Factor	0.451	0.430	0.491	0.442	0.545	0.475
Ellipticity (Rmin/Rmax)	0.991	0.992	0.994	0.996	0.997	0.997
RadiusX'/RadiusX'	0.999	1.000	1.002	1.000	1.001	0.999
RadiusY'/RadiusY'	1.001	1.000	0.998	1.000	0.999	1.001
3*RadiusX'/WindowsizeX	0.674	0.643	0.738	0.662	0.817	0.712
3*RadiusY'/WindowsizeY	0.679	0.648	0.736	0.665	0.817	0.713
Comment:						

Fig.9.26: The menu item *Review 2nd Moment* in the menu *Presentation*

9.10.5 Caustic display (2D-display)

The results of the caustic measurement could be displayed with the menu item *Caustic* in the presentation menu. Fig.9.27 shows the calculated beam parameters on the left, either on the basis of the 86 % - radii or the moment evaluation according to ISO 11146. In the center of the picture a graphic shows the caustic development; the beam radii are applied over the beam spread direction. On the right there is the false color depiction of one measurement plane each together with the numerical results. The measurement planes are selectable with the mouse.

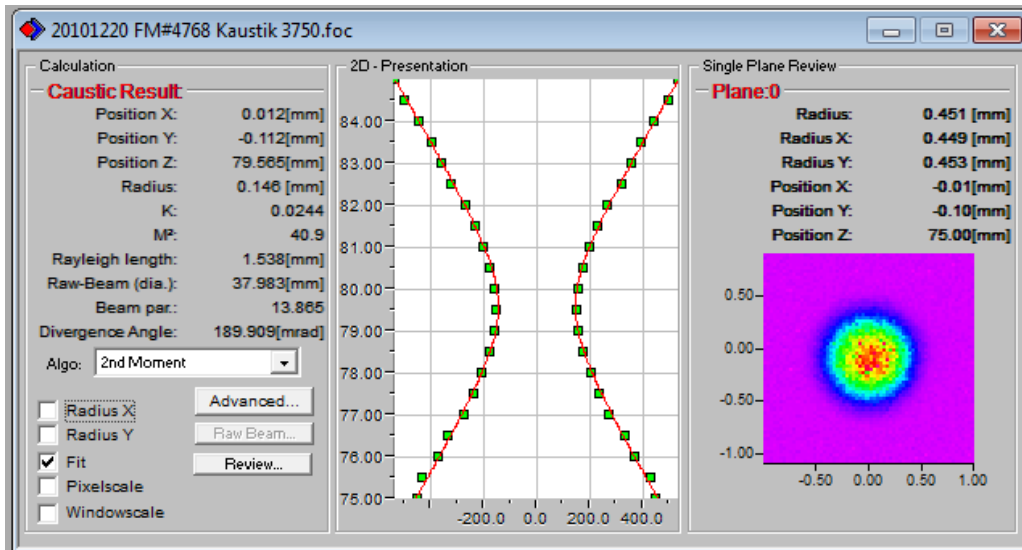

Fig.9.27: Dialogue window **Presentation>>Caustic**

The red line depicts the compensating curve according to the evaluated fits, it can be inserted in the display by means of activating the checkbox **Fit**.

- **Compensating curve**

For an accurate evaluation of the caustic a hyperbolic compensating curve (ISO 11146) is adapted to the measurement values. This compensating curve mathematically describes the propagation of an ideal laser beam. The development of the compensating curve is theoretically determined by the following parameters:

- standardized diffraction index M^2 or respectively beam propagation ratio
- z-position
- fokus radius
- rayleigh length

- **Standardized beam propagation ratio K (or respectively the diffraction index M^2)**

The standardized beam propagation ratio describes how well the respective laser beam can be focused in comparison with the basic mode. Theoretically, the basic mode is the best beam possible and has a beam propagation ratio of 1. All other beams have smaller values. With regard to welding lasers CO_2 they are at 0.2 up to 0.5. Concerning cutting lasers values from 0.4 to 0.9 are common. When it comes to beam sources with an increasing laser power the beam propagation ratios are generally smaller than in case of sources with a lower power.

- **Z-Position**

This value indicates the position of a focusing point in z-direction. As the compensating curve considers all measuring points the measured z-position is not compulsorily located at the point of the smallest beam radius measured.

- **Focus radius**

The focus radius is the smallest beam radius in the caustic. Generally, this value is similar to the smallest value measured. For different reasons it may occur that no adaption to the measuring values was carried out. This is recognizable from the fact that the compensating curve lies next to the measurement values or is not displayed at all. In this case the parameters of the adapted compensating curve are to be used.

- **Rayleigh length (z_R)**

The Rayleigh-length is a derived parameter and describes the distance from the focus in z-direction in case of which the beam radius has increased by the square root of 2 (=1.41) and the beam area has increased by the factor two. The Rayleigh-length increases with the beam propagation ratio and the focal length of the focusing optics. The doubled Rayleigh length is an approximate indication up to which material thickness (metal) a processing with the used optics is possible.

In order to ensure that the adapted values have a high accuracy it makes sense to extend the measurement over a z-range which has a size of at least two Rayleigh lengths. A range of a quadruple Rayleigh length – as demanded in ISO 11146 – would be even more recommendable. This claim is, however, confronted with the sometimes fast sinking power density of the laser beam which is to be measured. In case of a distance of two Rayleigh lengths from the focus the power density has fallen to one quarter. In this case the caustic measurement consists of a compromise between the desired measurement range in the z-direction and the power density (signal-to-noise ratio) necessary for a faultless measurement.

In order to investigate asymmetric beams it is possible to determine the dimensions of the main axes of the beams. Based on these values the program also calculates direction dependent beam propagation ratios and beam position values. The associated curves are inserted via the two check boxes x, y, the numerical values are provided by the detail menu.

- **Cyclical caustic measurement**

In case of cyclical caustic measurements it makes sense to store the settings of the different recording parameters in a file. These data are then available at any time and can be used to carry out a new measurement. For a “fast” control of the beam a measurement with only a few planes is recommendable whereas – if required – only a part of the caustic is measured because for instance the gas nozzle is still mounted.

Such a measurement cycle is generally carried out in 2 to 3 minutes. In this case it also makes sense to connect the HP-MSM-I with the system control via the PLC interface so that the laser can be switched on and off program-controlled by the LaserDiagnosticsSoftware.

For a check-up after a laser- and system maintenance a measurement with several planes is recommended because the measurement results are determined with a higher accuracy then.

In order to start the measurement the stored caustic data are loaded from a pre-setting file. This is effected with the menu item **Load measurement preferences** in the menu item **File**. After entering the desired file name, the corresponding data are loaded.

9.10.6 Symmetry check

An interesting feature for the display of the symmetry control. For special devices this is available. This display menu controls the rotational symmetry of the power density distribution of the laser beam. It can be used with the **Monitor** – operation for the alignment of laser resonators.

In the following you can find two examples for the possible results of the symmetry control in the figures Fig.9.28 to Fig.9.29

- at an elliptic beam
- at a beam with rotational symmetry

along a section with 86 % of the power.

The power density distribution of an elliptic beam as displayed Fig.9.28 results in the following by means of the *symmetry check*.

The abscissa shows the angle as well as the ordinate of the beam radius with the intersection lines at different powers between 86 % and 10 % of the total power. On the screen curves in different colors appear. The radius is displayed in pixel coordinates. The minimum as well as the maximum of the radius values can be selected. On the right the standard deviation of the different radius values is depicted. This values give a detailed information regarding the symmetry of the beam distribution.

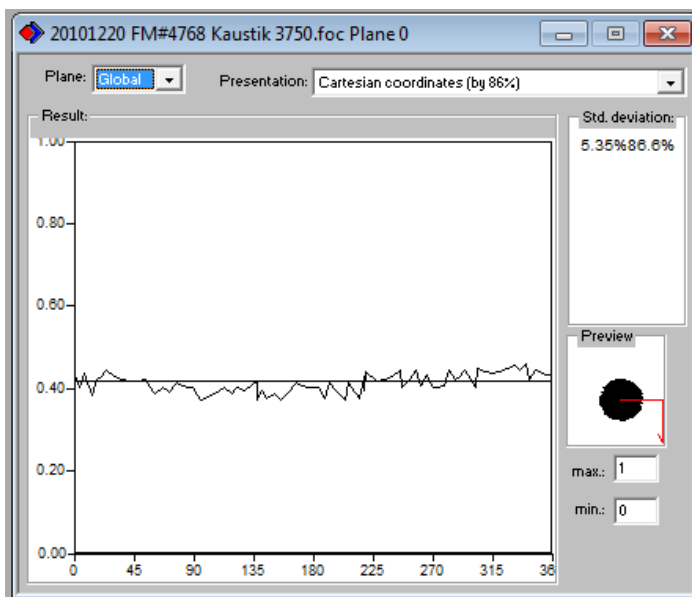

Fig.9.28: Presentation in the menu *symmetry check* in cartesian coordinates

Well aligned resonators reach a standard deviation in the range of 3 % to 5 %.

The display in polar coordinates is also possible (Fig.9.29). The lines drawn in include 86 % up to 10 % of the detected power. On the screen the graphs have different colors. X- and y- axis scale in pixel values.

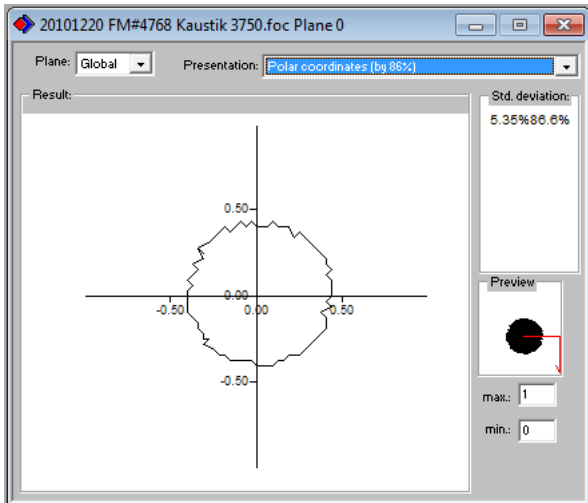

Fig.9.29: Symmetry check in polar coordinates

9.10.7 Fixed contour lines

The intersection lines are displayed at different power levels. Intersection lines are chosen at: 86 %, 80 %, 60 %, 40 %, 20 % and 10 % of the total power.

In this display you can also measure distances by clicking the starting point and end point of the desired distance with your mouse.

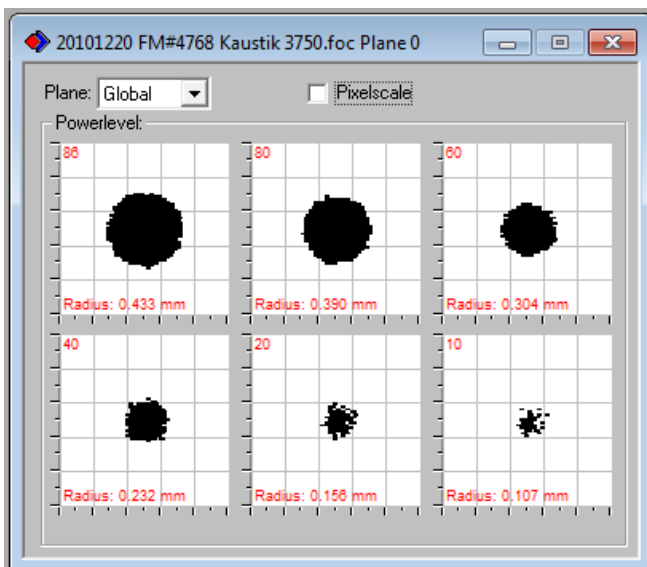

Fig.9.30: The display menu item *Fixed contour lines*

9.10.8 Variable contour lines

The spatial power density distribution is displayed by means of freely selectable sections. Sections in x- and y-direction as well as in power density coordinates (ADW-counts) can be carried out. The position of the sections can be adjusted by means of a slide control or the keyboard. The setting of the keyboard is effected as follows:

- For the x-direction via the key **x** in order to increase the value and **<shift>x** in order to decrease it.
- For the y-direction via the key **y** in order to increase the value and **<shift>y** in order to decrease it.
- For the power density (intensity) via the key **i** in order to increase the value and **<shift>i** in order to decrease it.

In the range in the left bottom corner the current section coordinates, power densities, the radius generated by means of the section as well as the volume are displayed. On the right you can switch to the scaling known from the chapter “False colors”. Underneath there is an input field where the desired power drop for the radius determination can be entered. Apart from these functions this window offers many more information regarding the conditions under which the measurement was drawn up.

Moreover, the amplification, the number of averages as well as the rotation speed of a scanning system during a measurement are displayed.

9.10.9 Graphical review

The menu *Graphical review* enables the user a number of possibilities to display the measuring values.

In the x-axis the power, the time, the planes or the z-position can be entered. For the y-axis the data of the radius, the x- or – respectively – the y-position as well as the angle is at your disposal. A total of 16 graphs can be displayed in this window.

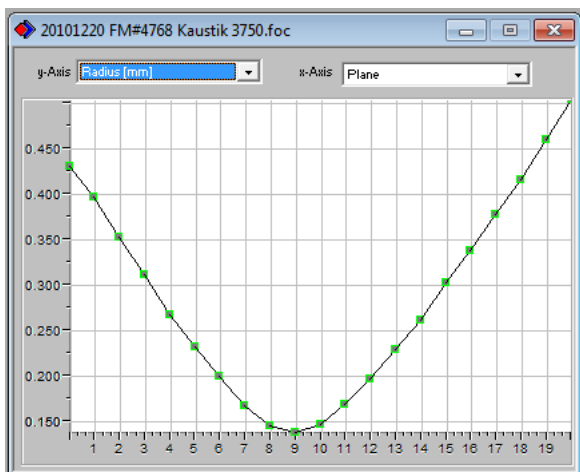

Fig.9.31: Graphical review

9.10.10 Color tables

There are different color charts available. The software enables a switching between the color charts. Due to this, the assignment of A/D converter values and the different color scales can be varied. This is important for every false color depiction.

Three settings are possible:

- Linear color table
- Color table analogous to the root function
- Color table analogous to the fourth root function

These functions can be useful especially when it comes to the analysis of slight variations near the zero level, e.g. for the analysis of diffraction phenomena.

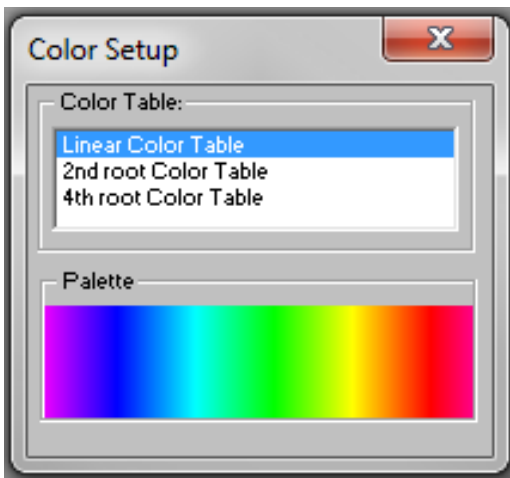

Fig.9.32: Color tables

9.10.11 Position

The menu enables the movement of the device into the desired position.

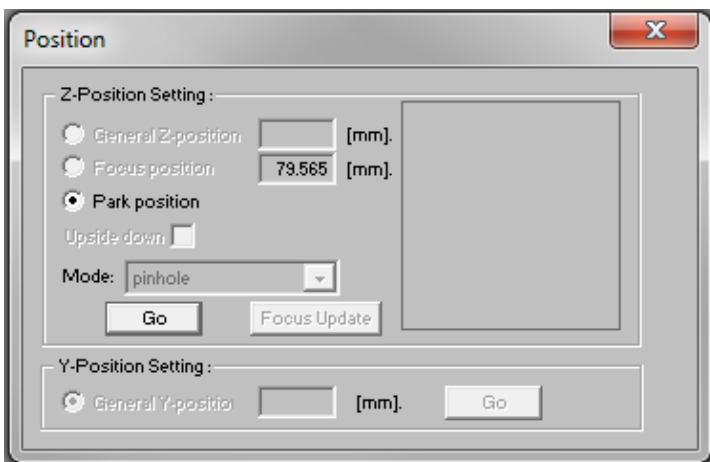

Fig.9.33: Menu *Position*

9.11 File administration

Further functions include – among others - the administration of measurement- and setting data.

9.11.1 New

By means of *New* a new file can be created.

9.11.2 Open

By means of *Open* a file which is to be loaded can be chosen and opened.



Fig.9.34: Opening an existing file

9.11.3 Save

The common *Save file* operations are used here as well.

The standard type is a binary data format with a minimal memory requirement. The file ending for the measurement file of this type is '**.foc**'. As an alternative, you can store the data in ASCII format with the extension '**.mdf**'. Only files with this ending can be opened by the program.

9.11.4 Save as

In order to store measurement data in a file, please choose *Save as...* and type in a name and a register. When storing your data you can choose from two different file formats.

Please only save the measurement data only with the extension '**.foc**' or '**.mdf**'. Measurement data can only be observed if the respective file was explicitly chosen in the toolbar!

9.11.5 Export

Writes the numerical measurement values (only ADC values) of existing measurement data into a tab-separated text file (.xls) which can then be imported to Microsoft Excel. As an alternative the numerical results of the calculation can be saved in a protocol file (*.pkl).

9.11.6 Load measurement preferences

Settings which have already been stored can be made the current settings again by means of *Load measurement preferences*. The standardized extension for a setting file is '**.ptx**'.

9.11.7 Save measurement preferences

Saves current measurement settings.

9.11.8 Protocol

This menu item enables the writing of the calculated measurement results into a text file. The following information is stored:

- Date and time of the measurement
- Beam position and beam radius (according to 86 %- and 2nd moment definition)

Please therefore activate the check box **Write** in the field **protocol file**. Then you can directly type in the name in the input field **File name** or use the standard selection menu with the button **Select**.

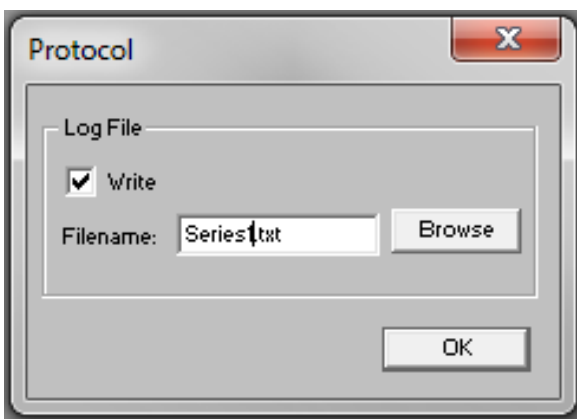

Fig.9.35: The menu *Protocol*

9.11.9 Print

The printer can be accessed directly from the program. The current window can be printed via **File >> Print**. Settings of formats etc. are possible via the menu item **Printer settings**.

9.11.10 Print preview

In order to check what the print would look like, you can use the function **Print preview**.

9.11.11 Recently opened file

Here you can choose the file edited last.

9.11.12 Exit

Terminates the program.

9.12 Edit

9.12.1 Copy

By means of the copy function a direct export of graphics into other programs is possible. The content of the current window is then transferred to the Windows clipboard.

9.12.2 Clear plane

The content of the currently displayed measurement plane of the measurement data set which is chosen in the toolbar is deleted.

9.12.3 Clear all planes

The content of all measurement planes of the measurement data set which is chosen in the toolbar is deleted.

9.12.4 Change user level *OPTION*****

By typing in a password you can activate a different user interface.

10 Measure

NOTICE

There is a danger of damage

Please check the following requirements before each measurement:

- ▶ The swiveling range of the shutter is free
- ▶ The measuring device is mounted solidly
- ▶ The cooling water is connected and a sufficient water flow rate is ensured (at least 4 l/min).
- ▶ The compressed air is connected and a sufficient air flow rate is ensured (4 bar ... 5 bar)
- ▶ The safety circuit is connected and its functions are checked

10.1 Manual operation (script control)

In this operating mode you can choose and start or – respectively stop complex measurement programs via the graphical user interface (tab Operating mode). The scripts are written in the script language Python (according to version 2.6) which was supplemented by PRIMES-specific commands.

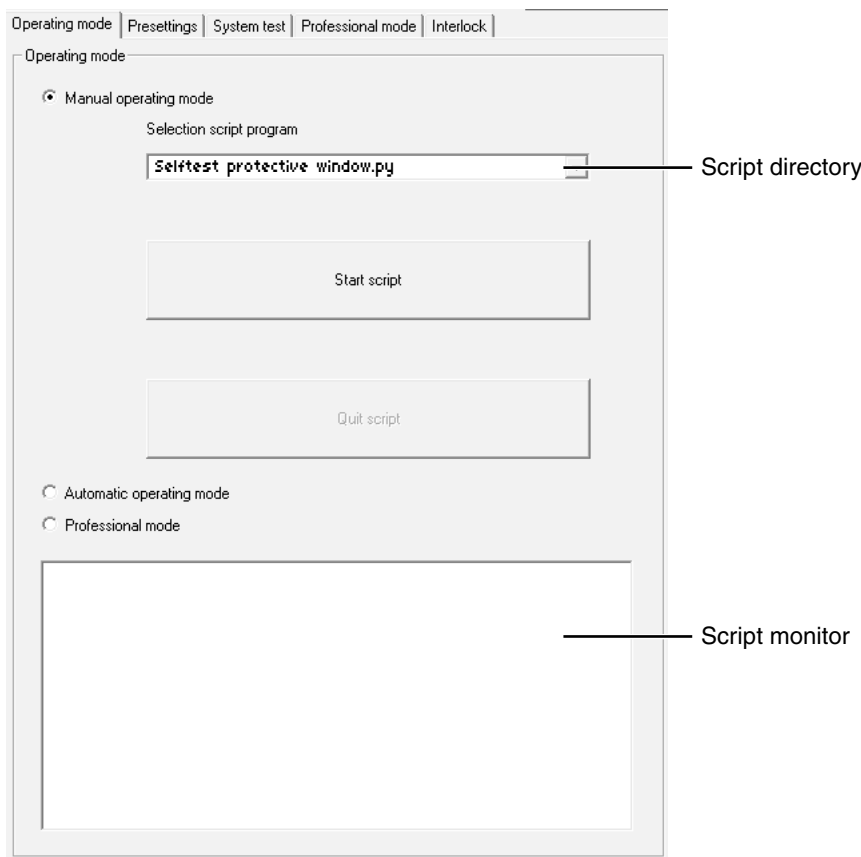

Fig.10.1: Script selection

For the operation a few data sets are needed. These contain the respective measurement settings (.ptx-files) and evaluation parameters (.eval-files)

Script name	Function	Data Sets Needed	Option/Standard
Focus caustic Fiber.py	Measurement of a focusing optic through the fiber input	FokusCaustik_fiber.ptx Beamparams_fiber.eval	O
Fokus caustik Beam.py	Measurement of a focusing caustic through the process input	FokusCaustik_beam.ptx Beamparams_beam.eval	O
Fokus shift Fiber.py	Measurement of the focus shift via the laser power through the fiber input	FokusShift_fiber.ptx	O
Focus Shift Beam.py	Measurement of the focus shift via the laser power through the process input	FokusShift_beam.ptx	O
Power characteristic curve Fiber.py	Measurement of the power characteristic curve through the fiber input	PowerCharacteristicCurve_Fiber.ptx	O
Power characteristic curve Beam.py	Measurement of the power characteristic curve through the process input	PowerCharacteristicCurve_Beam.ptx	O
Self-test Protective Window.py	Calibration of the protective window (protective window test) through the fiber input	ProtectiveWindowTest.ptx ProtectiveWindowTest.eva	S
Qualification of all protective windows.py	Calibration of all protective window through the fiber input	ProtectiveWindowTest.ptx ProtectiveWindowTest.eval	O
Self-test power calibration.py	Execution of an independent power calibration (EC-test)	No data set necessary	O
Time constant focus shift warm up	Determination of the warm up pattern of the laser (process input)	FocusShiftTimeConstant_beam_warmup.ptx	O
Time constant focus shift cool down.py	Execution of the cool down pattern of the laser (process input)	FocusShiftTimeConstant_beam_cooldown.ptx	O

Tab.10.1: Overview of the scripts for the manual operating mode

The data sets are drawn up in the expert operating mode. After the “calibration” of the data sets it is then possible to switch to the manual operating mode.

The available scripts are listed in the script index of the tab *Operating mode* (please see Fig.10.1).

- Please click the button **Start script** in order to carry out a chosen script
- Please click the button **Quit script** in order to stop the execution of the script

When it is stopped, a message saying that the measuring procedure was interrupted appears on the screen immediately. However, the measuring device may still be in the running routine. Therefore the device may not immediately be ready for the next measurement.

When a script is started you are guided through the measurement program. The dialogue is effected via a combination of dialogue windows and status indications in the script monitor which have to be confirmed. Sometimes a manual release by means of a hand switch at the device is also necessary (hand switch included in delivery).

In the following the course of all necessary interactions is described for each measuring program.

10.1.1 Script “Focus Caustic Fiber” **OPTION**

Task:

The measurement of a caustic at the fiber input. The measurement values are compared with a parameter set. The result of this comparison is then displayed in the traffic light display.

The following input files have to be included in the script index:

- Measurement setting file **FocusCaustic_fiber.ptx**
- Parameter set file **Beamparams_fiber.eval**

Should one of the input file not be available, the script stops with an error message.

Output files:

- Measuring file **FocusCaustic_fiber_TIME.foc**
- Parameter set file **Beamparams_fiber_TIME.eval**

The output files are stored in the preselected storage directory.

Script course:

Load the parameter set file
Load the measurement settings

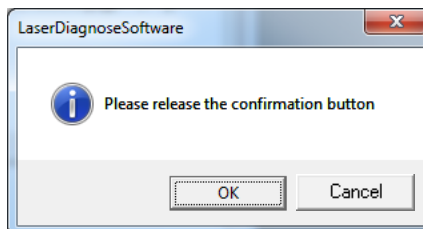
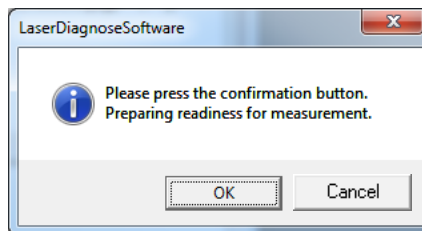

Switch on the laser

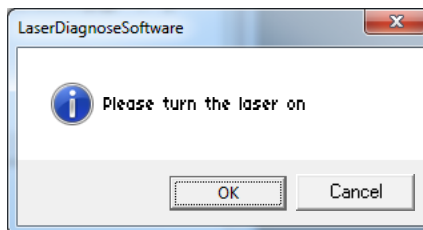

Measure the caustic and evaluate the results

Store the measured values

Switch off the laser

10.1.2 Script "Focus Caustic Beam" ****OPTION****

Task:

Measurement of a caustic at the process input. The measuring values are compared with a parameter set. The result of this comparison is displayed in the traffic light display.

The following input files have to be included in the script index::

- Measurement setting file ***FocusCaustic_beam.ptx***
- Parameter set file ***Beamparams_beam.eval***

Should one of the input files not be available the script stops with an error message.

Output files:

- Measurement file ***FocusCaustic_beam_TIME.foc***
- Parameter set file ***Beamparams_beam_TIME.eval***

The output files are stored in the preselected storage directory.

Script course:

Open the shutter and load the measurement settings

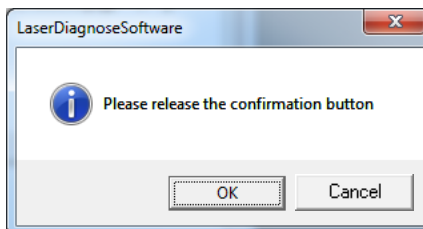
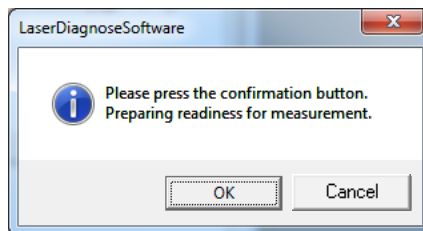

Switch on the laser

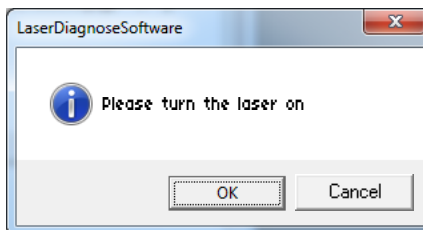

Measure the caustic and evaluate the results

Store the values measured

Switch off the laser

10.1.3 Script “Focus Shift Fiber” **OPTION**

Task:

Measurement of two caustics and the calculation of the deviations of the focus position in z-direction at the fiber input. The measuring values are compared with a parameter set. The result of this comparison is then displayed in a traffic light display.

The following input file has to be included in the script index:

- Measurement setting file **FocusShift_fiber.ptx**

Should the input file not be available the script stops with an error message.

Output file:

- Measurement file **FocusShift_fiber_TIME.foc**

The output files are stored in the preselected storage directory.

Script course:

Switch off the laser

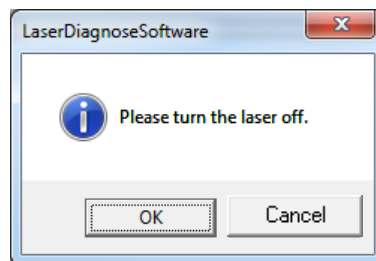

Open the shutter and load the measurement settings

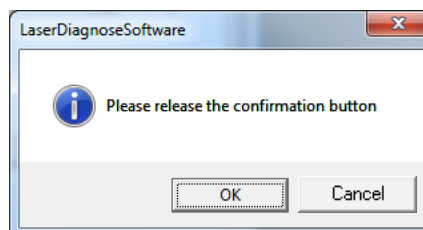
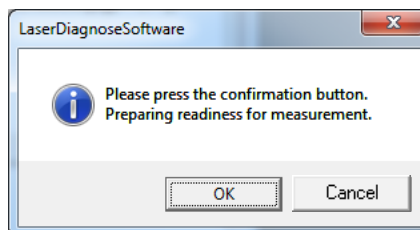

Measure a caustic with 10 % laser power

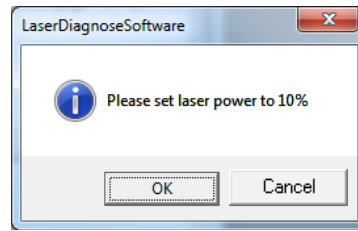

Measure a caustic with 100 % laser power

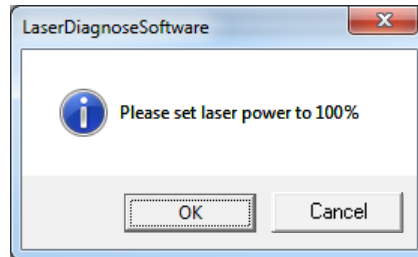

Store the measurement results

Switch off the laser

10.1.4 Script "Focus Shift Beam" ****OPTION****

Task:

Measurement of two caustics and calculation of the deviation of the focus positions in z-direction at the process input. The measurement values are compared with a parameter set. The result of this comparison is displayed in the traffic light display.

The following input file has to be included in the script index:

- Measurement setting file ***FocusShift_beam.ptx***

Should the input file not be available the script stops with an error message.

Output file:

- Measurement file ***FocusShift_beam_TIME.foc***

The output files are stored in the preselected storage directory.

Script course:

Switch off the laser

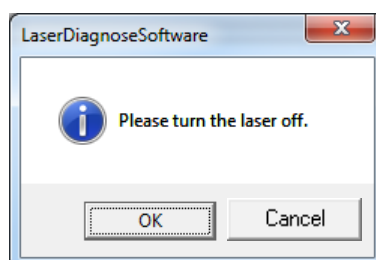

Open the shutter and load the measurement settings

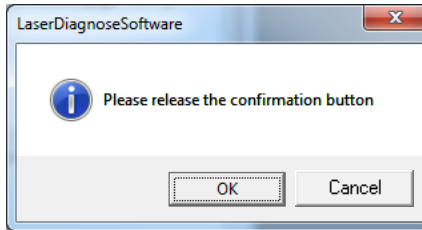
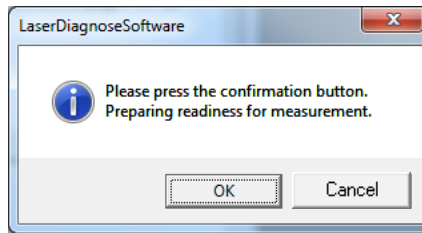

Measure a caustic with 10 % laser power

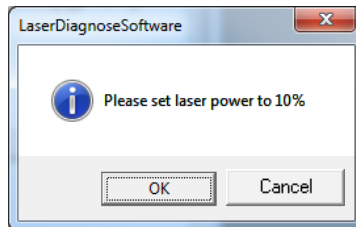

Measure a caustic with 100 % laser power

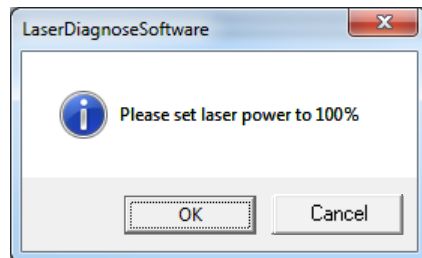

Store measurement results
Switch off the laser

10.1.5 Script “Characteristic Curve Fiber” **OPTION**

Task:

Measurement of the characteristic line of the laser in the steps 10 %, 20 %, 40 %, 80 % and 100 % at the fiber input. After the confirmation of the actual power a thermalization of 90 s is effected. Afterwards 20 power measurement values are determined and the average value is formed. For the recording the results are stored in a text file.

The following input file has to be included in the script index:

- Measurement setting file ***CharacteristicCurve_fiber.ptx***

Should the input file not be available the script closes with an error message.

Output file:

- Measurement file ***FocusShift_beam_TIME.foc***

The output files are stored in the preselected storage directory.

Script course:

Open the shutter and load the measurement settings

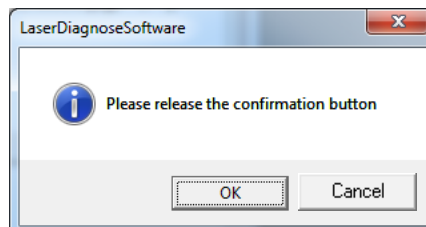
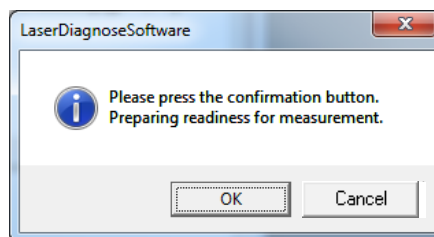

Measure the power in the respective power steps.

After the confirmation of the actual power a thermalization of over 90 s is effected.

Afterwards 20 measurement values are determined and the average value is stored in the output file.

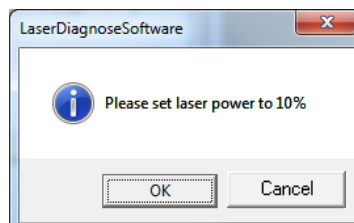

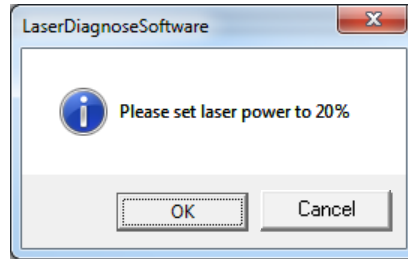

-
- 40 %
- 80 %
-
-

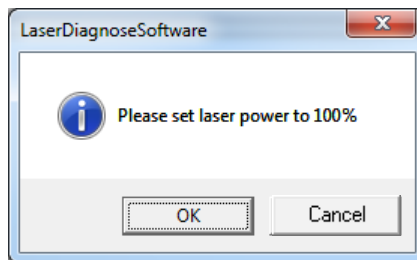

Switch off the laser

10.1.6 “Script “Self-test Protective Window”

Task:

Test whether the protective window is clean. Therefore two caustics are measured whose power values have to differ by at least 2000 W. Both measurements are compared with a parameter set. The result of this comparison is displayed as a traffic light display. The condition of the protective window is reported back to the user.

The following input files have to be included in the script file:

- Measurement setting file ***ProtectiveWindowTest.ptx***
- Parameter set file ***ProtectiveWindowTest.eval***

Should the input file not be available the script stops with an error message.

Output files:

- Parameter set file ***protectivewindowtest_lowpower_PROTECTIVEWINDOWNO_TIME.eval***
- Parameter set file ***protectivewindowtest_highpower_PROTECTIVEWINDOWNO_TIME.eval***
- Measurement file ***protectivewindowtest_lowpower_PROTECTIVEWINDOWNO_TIME.foc***
- Measurement file ***protectivewindowtest_highpower_PROTECTIVEWINDOWNO_TIME.foc***

The output files are stored in the preselected storage directory.

Script course:

Switch off the laser

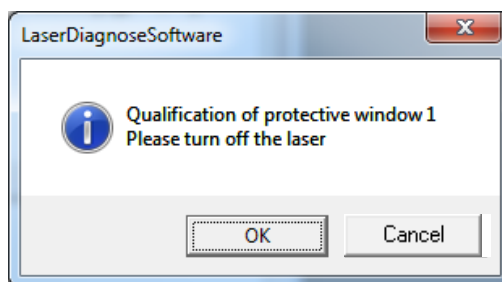

Load measurement settings

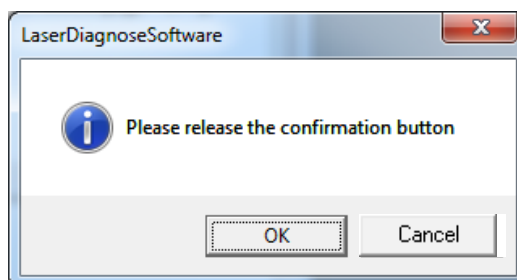
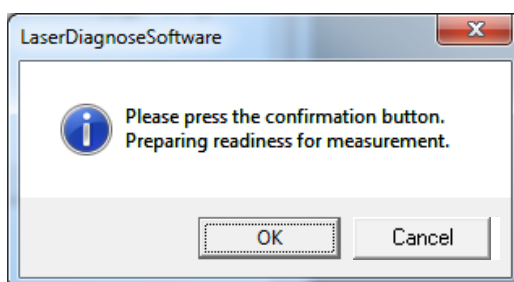

Measure a caustic with 10 % laser power

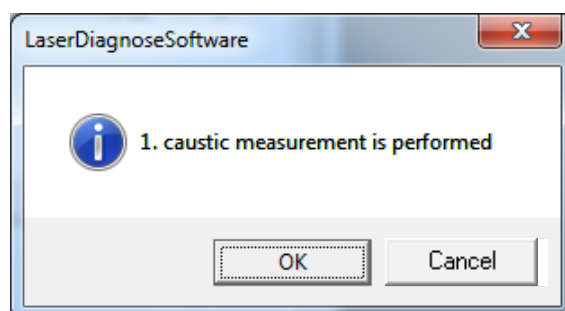
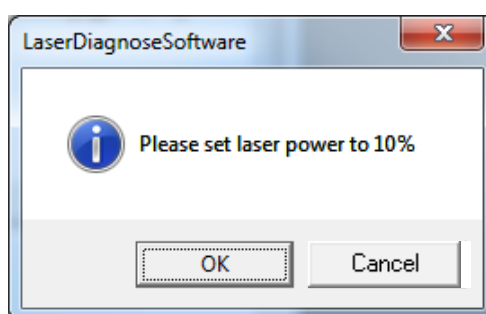

Evaluate the measurement

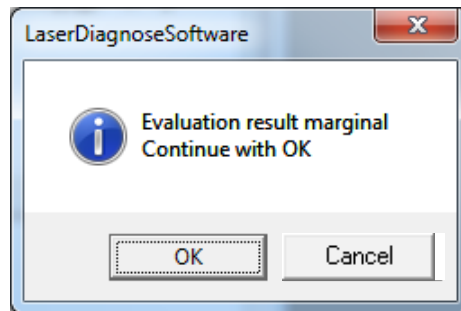

Measure a caustic with a high laser power

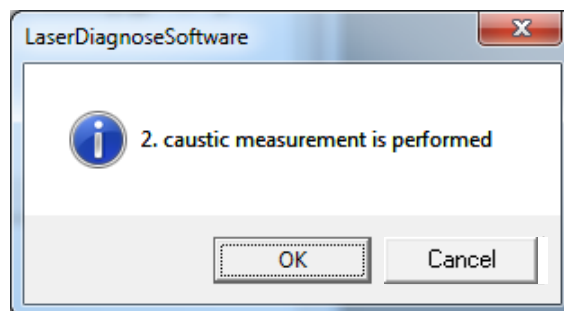
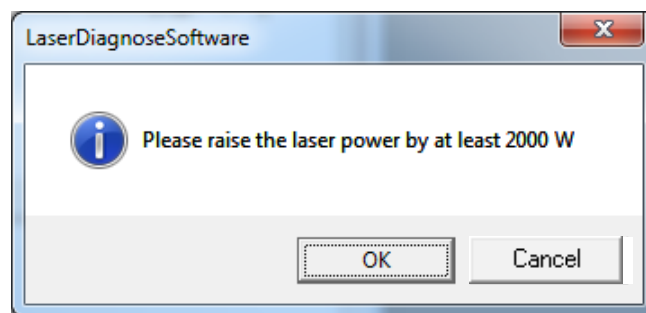

Evaluate the measurement

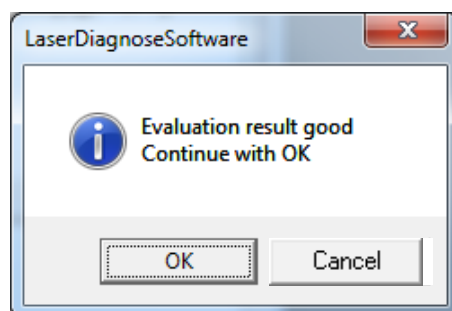

Save

Switch off the laser

Feedback of the protective window condition

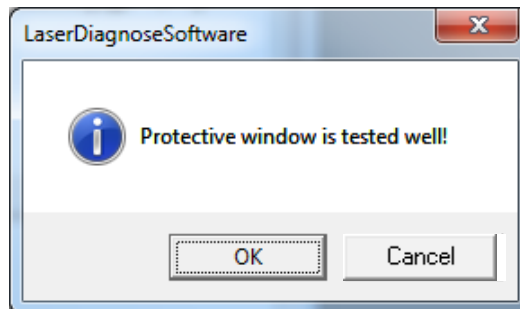

10.1.7 Script "Time Constant Focus Shift Cool Down" ****OPTION****

Task:

Measurement of the shift of the focus position when the laser cools down. Therefore a caustic with a high power is measured. Afterwards 50 planes in the focus plane are measured with low power.

The following input file has to be included in the script index:

- Measurement setting file ***Focusshifttimeconstant_beam_cooldown.ptx***

Should the input file not be available the script stops with an error message.

Output files:

- Measurement file ***Focusshifttimeconstant_beam_cooldown_TIME.foc***
- Measurement file ***Focusshifftimeseries_beam_cooldown_TIME.foc***

The output files are stored in the preselected storage directory.

Script course:

Load measurement settings

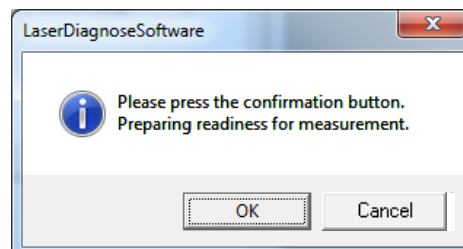

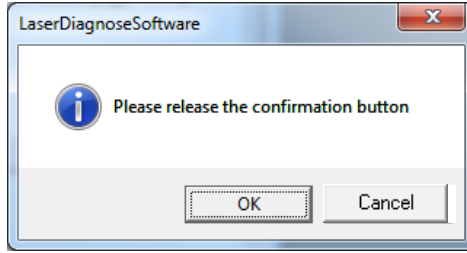

Measure a caustic with 100 % laser power

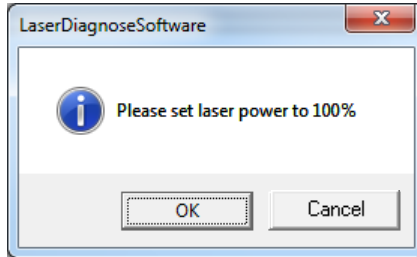

Save result

Measure 50 planes with 10 % laser power in the focus position

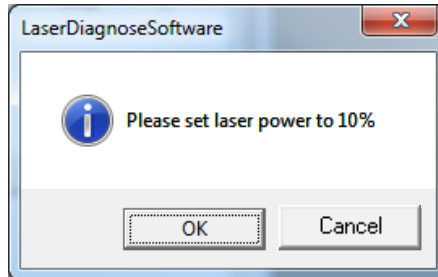

Switch off the laser

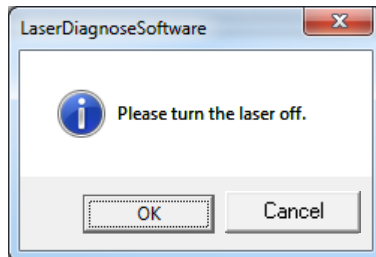

Save measurement results

10.1.8 Script “Time Constant Focus Shift Warm Up” ****OPTION****

Task:

Measurement of the shift of the focus position when the laser warms up. Therefore a caustic with low power is measured. Afterwards 50 planes in the focus plane are measured with high power.

The following input file has to be included in the script:

- Measurement setting file ***Focusshifftimeconstant_beam_warmup.ptx***

Should the input file not be available the script stops with an error message.

Output files:

- Measurement file ***Focusshifftimeconstant_beam_warmup_TIME.foc***
- Measurement file ***Focusshifftimeseries_beam_warmup_TIME.foc***

The output files are stored in the preselected storage directory.

Output files:

Load measurement settings

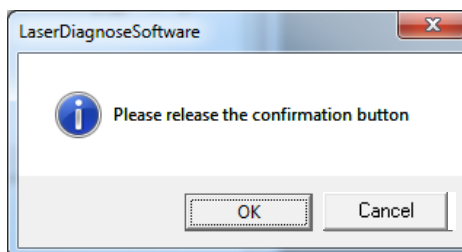
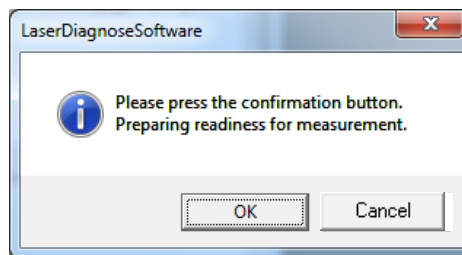

Measure a caustic with 10 % laser power

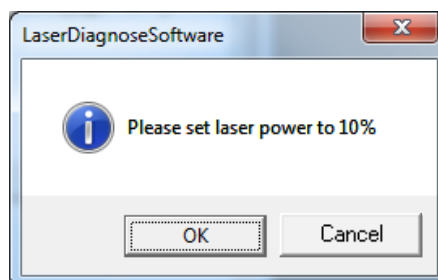

Save the result

Measure 50 planes with 100 % laser power in the focus position

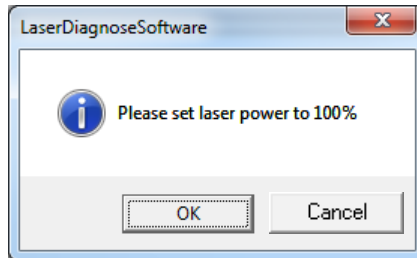

Switch off the laser

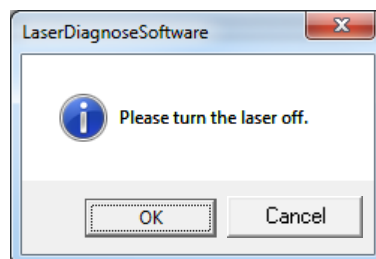

Save measurement results

10.1.9 "Self-Test Power Calibration" ****OPTION****

Task:

Carry out a power calibration. For the self-test an electronic calibration function is included in the device.

Output file

- Measurement file ***ec-files.txt***

The output file is stored in the preselected storage directory.

Script course:

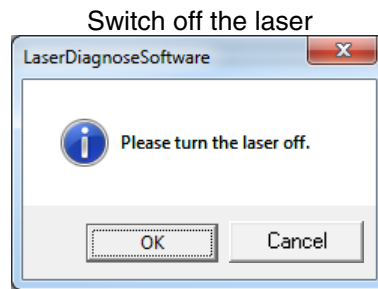

Thermalization

Measure values

Form average value and calculate deviation

Save results

10.1.10 Script “Qualification of all Protective Windows” *OPTION*****

Task:

All protective windows of the measurement device are to be checked for contaminations. Therefore the procedure “Self-Test Protective Window” is carried out for all protective windows.

The following input files have to be included in the script index:

- Measurement setting file ***Protectivewindowtest.ptx***
- Parameter set file ***Protectivewindowtest.eval***

Should the input file not be available the script stops with an error message.

Output files (for each protective window):

- Parameter set file ***protectivewindowtest_lowpower_protectivewindowno_TIME.eval***
- Parameter set file ***protectivewindowtest_highpower_protectivewindowno_TIME.eval***
- Measurement file ***protectivewindowtest_lowpower_protectivewindowno_TIME.foc***
- Measurement file ***protectivewindowtest_highpower_protectivewindowno_TIME.foc***

The output files are stored in the preselected storage directory.

Script course:

Approach the first protective window

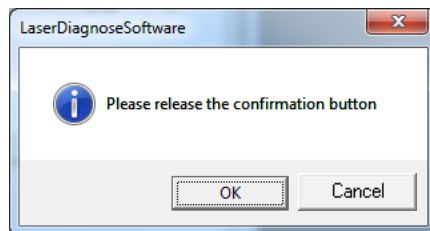
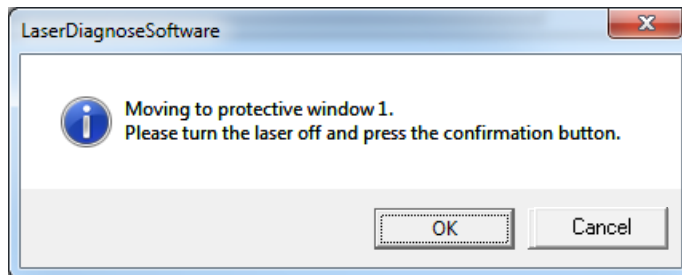

Carry out the self-test protective window

Approach next protective window

10.2 Automatic operating mode

In case of the automatic operating mode the control of the HP-MSM-I is taken over by the system. The communication with the system is effected via the PLC connections (please see chapter 8.5 on page 28). In order to switch to the automatic operating mode the system has to switch the input line 14 to high level (please see Tab.8.5 on page 31). In order to ensure that the HP-MSM-I switches to the automatic operating mode correctly after it is ready for operation this line has to be connected with 24 V.

The following automatic scripts are available:

1. Open shutter

Goal: Opens shutter

Configuration: none

Input files: none

Output files: none

2. Close shutter

Goal: Closes shutter

Configuration: none

Input files: none

Output files: none

3. Next protective window

Goal: Moves the protective window exchanger onto the next protective window

Input files: none

Output files: none

4. Next clean protective window

Goal: Moves the protective window exchanger onto the next clean protective window

Configuration: none

Input files: none

Output files: none

Further details regarding the register addresses, data fields and their values can be found in the chapter „11.5.1 Command 1 (Cmd1)“ on page 127.

5. Measurement programs

Adjustable parameters can be found in the file “GlobalSettings.py”. You can adjust them in order to change, for instance, the settling time for a power measurement (please see chapter 10.2.1 on page 96). The file can be found in the lib directory of the LaserDiagnosisSoftware. The path to this directory has to be adjusted to your computer configuration (standard path “C:\LaserDiagnosisSoftware\pyscript\lib”).

The input files are located in the script index, the path can be configured in the file “Laserds.ini”.

Example:

[File]

MSMI Script Save Path=E:\LDS2\scripts

The output files are located in the script index, the path can be configured in the file “Laserds.ini”.

Example:

[File]

MSMI Save Path=E:\LDS2

10.2.1 Global settings

The file “GlobalSettings.py” can be edited with an arbitrary text editor. Please take the following aspects into consideration:

- Do not use any tabs, for example in order to insert. Each place holder or line insertion has to consist of 4 spaces.
- The order of the parameters in the file can be changed.
- Comments can be pasted line-by-line. Each comment line has to start with a “#”-sign.

In the following example the parameters included in this file are described. The parameters which are marked in red and which are equipped with the respective comment line are intended for the procedures of other measurement tasks and devices. They are irrelevant for the use of the HP-MSM-I.

Example:

(The entries marked with a ***** are configuration parameters for optionally available programs).

#Globally valid Timeout specification for interactions in the system (e.g. maximum waiting time for recognition of laser power); the indication is made in s

***** **giWaitCounter = 100**

#Number of power measurements by means of which the averaging is effected in case of the exclusive power measurement; the indication is made in the number of the desired measurements

***** **giPowerNumVals = 2**

#Below this measured laser power the laser is recognized as switched off; the indication is made in W
giMaxPowerForLaserOff = 50.0

#Power difference for the recognition of the turn-on process of the laser; from this
#Power difference to the zero performance the laser is recognized as switched on; the indication is effected in W
giPowerDifferenceForLaserOn = 40.0

#Indication of the plane numbers which are re-measured whenever the measurement program “fast measurement” is selected an arbitrary number of planes can be selected; the planes are indicated directly with their number in squared brackets; it is prohibited
#select plane numbers, which are not configured according to the pre-measured caustic in the ptx file

***** **giPlaneListForFastMeasurement = [7, 11]**

#Stipulation of the percental power steps which are to be measured for the measurement of the focus shift is effected in % of the maximum laser power within the squared brackets; only two values - separated by a comma - from the following power steps may be stated: 0, 5, 10, 20, 40, 80, 100

***** **giFocusShiftPowerValues = [10, 20]**

#Stipulation of the power steps for the validation of the protective windows;
#the indication is effected in % of the maximum laser power within the squared brackets; only two values – separated by a comma – from the following power steps may be stated: 0, 5, 10, 20, 40, 80, 100
giProtectionGlassPowerValues = [10, 100]

#Stipulation of a safe position of the internal MSMi-z-axis in case of a measurement through the reference fiber input; this position is approached when the exclusive power measurement is selected. The indication is effected in μm
giSaveZPosFibreMeasurement = 110000

#Indication of a safe position of the internal MSM-I z axis in case of a measurement through the process beam input; this position is approached when the exclusive power measurement is selected. The indication is effected in μm .
giSaveZPosProcessMeasurement = 85000

#Thermalization time for the transient response of the power measurement; after the recognition of
#the laser power this time passes before the measurement starts; the duration refers to the exclusive
#power measurement and the complete measurement of the caustic; the indication is effected in s
giThermalizationTime = 10

#Activation of debug output during the measuring procedure; this parameter is not relevant for the
#Productive employment of the MSM-I; the indication is effected binarily: 0 --> no issue of the
#debug message, 1 --> issue of a debug message
giDebug = 0

#for MSM-I automated operation is not relevant
giDebugEvalv = 1
giDebugEvalValue = 2

10.2.2 Fiber Test ****OPTION****

Goal: Self-test HP-MSM-I regarding optic and protective window, tidiness of the current protective window.

Execution: 2 caustics are measured. The laser power is requested by the LDS.

Configuration in the file "GlobalSettings.py": **giProtectionGlassPowerValues=[10, 100]**
1st caustic measured with 10 %, 2nd caustic measured with 100 % laser power.

Input files:

- ProtectivewindowTest_10.eval
- ProtectivewindowTest_10.ptx
- ProtectivewindowTest_100.eval
- ProtectivewindowTest_100.ptx

Output Files:

- ProtectivewindowTest_10_Time_ProtectivewindowNo.eval
- ProtectivewindowTest_10_Time_ProtectivewindowNo.ptx
- ProtectivewindowTest_10_Time_ProtectivewindowNo.foc
- ProtectivewindowTest_10_Time_ProtectivewindowNo.journal
- ProtectivewindowTest_100_Time_ProtectivewindowNo.eval
- ProtectivewindowTest_100_Time_ProtectivewindowNo.ptx
- ProtectivewindowTest_100_Time_ProtectivewindowNo.foc
- ProtectivewindowTest_100_Time_ProtectivewindowNo.journal

Output parameter: none

10.2.3 Extended Measuring ****OPTION****

Goal: detailed focus measurement.

Execution: 1 caustic is measured. The laser power is stipulated by the system.

Configuration: none

Input files:

- FocusCaustic_long_10.eval
- FocusCaustic_long_10.ptx

Output files:

- |
- FocusCaustic_long_10_time.eval
- FocusCaustic_long_10_time.ptx
- FocusCaustic_long_10_time.foc
- FocusCaustic_long_10_time.journal

Output parameter:

„MEANPOWER_PROC“, „FOC_RAD“, „FOC_RAD_X“, „FOC_RAD_Y“, „FOC_POS_X“, „FOC_POS_Y“, „FOC_POS_Z“, „M2“, „M2_X“, „M2_Y“, „BEAMDIR_X“, „BEAMDIR_Y“, „BPP“, „STD_DEV“, „RAYLEIGHT“, „DIVERGENCE“, „MAX_OPTICAL_LOAD“

10.2.4 Fast Measuring ****OPTION****

Goal: Fast focus measurement

Execution: Planes in a consisting caustic are measured. The laser power is stipulated by the system.

Configuration in the file "GlobalSettings.py": **giPlaneListForMeasurement = [1, 4, 7]**

The planes 1, 4, 7 are to be measured. An arbitrary number of measurement planes is possible.

Input files:

- FocusCaustic_short_10.eval
- FocusCaustic_short_10.ptx
- FocusCaustic_short_10.foc

(The number in the file name is to be chosen according to the desired percental laser power.)

Output files:

- FocusCaustic_short_10_time_ProtectivewindowNo.eval
- FocusCaustic_short_10_time_ProtectivewindowNo.ptx
- FocusCaustic_short_10_time_ProtectivewindowNo.foc
- FocusCaustic_short_10_time_ProtectivewindowNo.journal

Ausgabeparameter: Output parameter:

„MEANPOWER_PROC“, „STD_DEV“, „M2“, „BPP“

10.2.5 Long Term Measuring ****OPTION****

Goal: Determination of the focus shift between two caustics.

Execution: 2 caustics are measured. The laser power is requested by the LDS.

Configuration in the file "GlobalSettings.py": **giFocusShiftPowerValues = [10, 100]**

1st caustic measured with 10 %, 2nd caustic measured with 100 % laser power.

Input file:

- FocusShift_10.eval
- FocusShift_10.ptx
- FocusShift_100.eval
- FocusShift_100.ptx

(The number in the file name is to be chosen according to the desired percental laser power.)

Output Files:

- FocusShift_10_time.eval
- FocusShift_10_time.ptx
- FocusShift_10_time.foc
- FocusShift_10_time.journal
- FocusShift_100_time.eval
- FocusShift_100_time.ptx
- FocusShift_100_time.foc
- FocusShift_100_time.journal

Output parameter:

FOCUSSHIFT

10.2.6 Power Measuring Process *OPTION*****

Goal: Power measurement at the process input

Execution: Power values are measured. The laser power is stipulated by the system.

Configuration in the file "GlobalSettings.py": **giPowerNumVals = 20**
20 power values are to be measured

Input files:

- PowerProcess_10.eval
- PowerProcess_10.ptx

(The number in the file name is to be chosen according to the desired percental laser power.)

Output files:

- PowerProcess_10_time.txt
- PowerProcess_10_time.ptx
- PowerProcess_10_time.journal

Output parameter:

MEANPOWER_PROC

10.2.7 Power Measuring Fibre *OPTION*****

Goal: Power measurement at the fiber input

Execution: Power values are measured. The laser power is stipulated by the system.

Configuration in the file "GlobalSettings.py": **giPowerNumVals = 20**
20 power values are to be measured

Input files:

- PowerFiber_10.eval
- PowerFiber_10.ptx

Output files:

- PowerFiber_10_time.txt
- PowerFiber_10_time.ptx
- PowerFiber_10_time.journal

Output parameter:

MEANPOWER_FIBRE

10.2.8 Electrically Calibration Test ****OPTION****

Goal: Self-test power part HP-MSM-I (EC-measurement).

Execution: An EC-measurement is carried out.

Configuration: none

Input files: none

Output files:

- EC_time.txt
- EC_time.ptx
- EC_time.journal

Output parameters:

EC

10.3 Example for a First Measurement (Professional Mode)

10.3.1 Plan of procedure for the first measurement

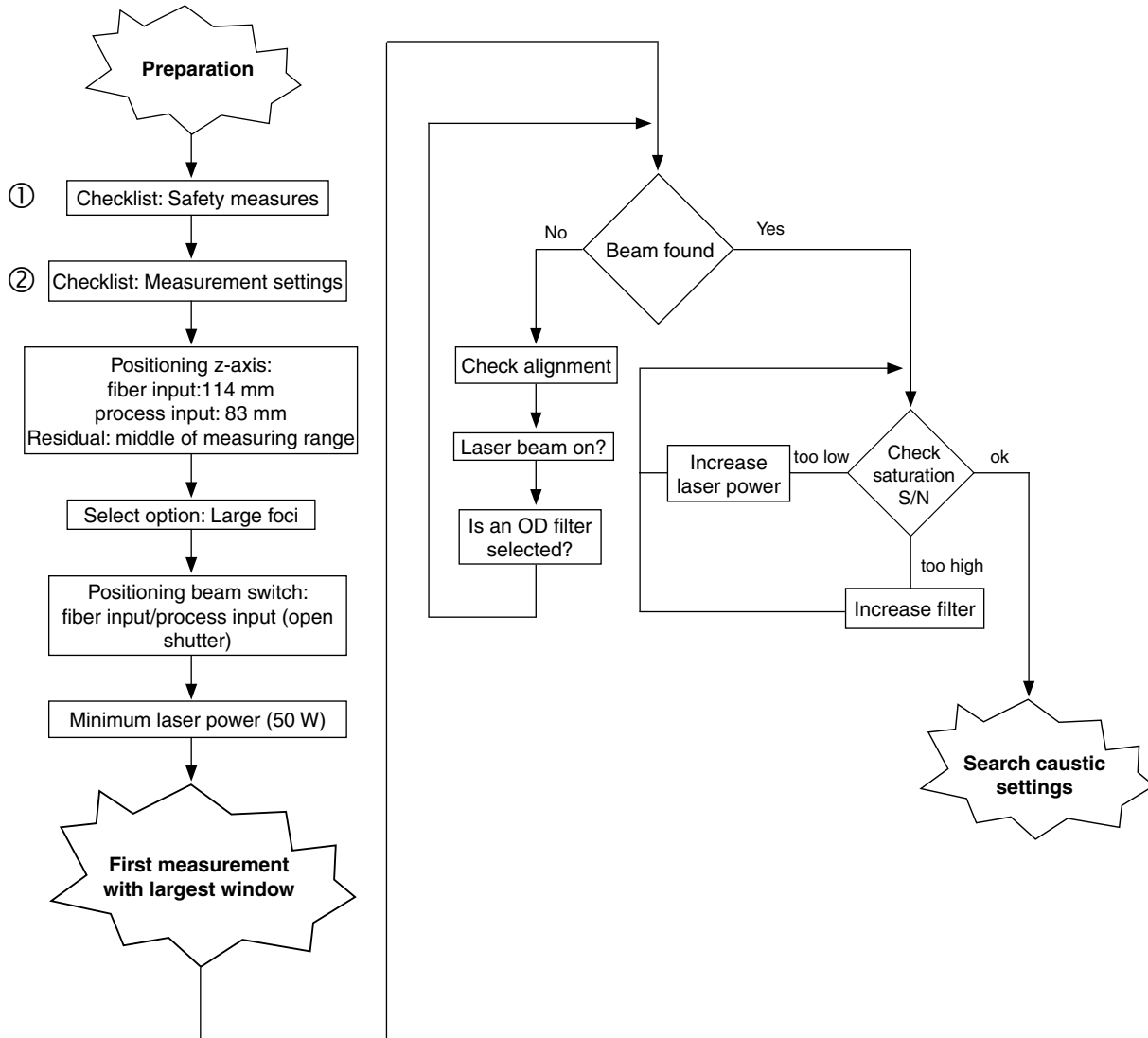

① Please see chapter „10 Measure“ on page 78

② Please see chapter „9.8 Basic settings for a fast CW measurement“ on page 44

10.3.2 Plan of procedure for the determination of caustic limits

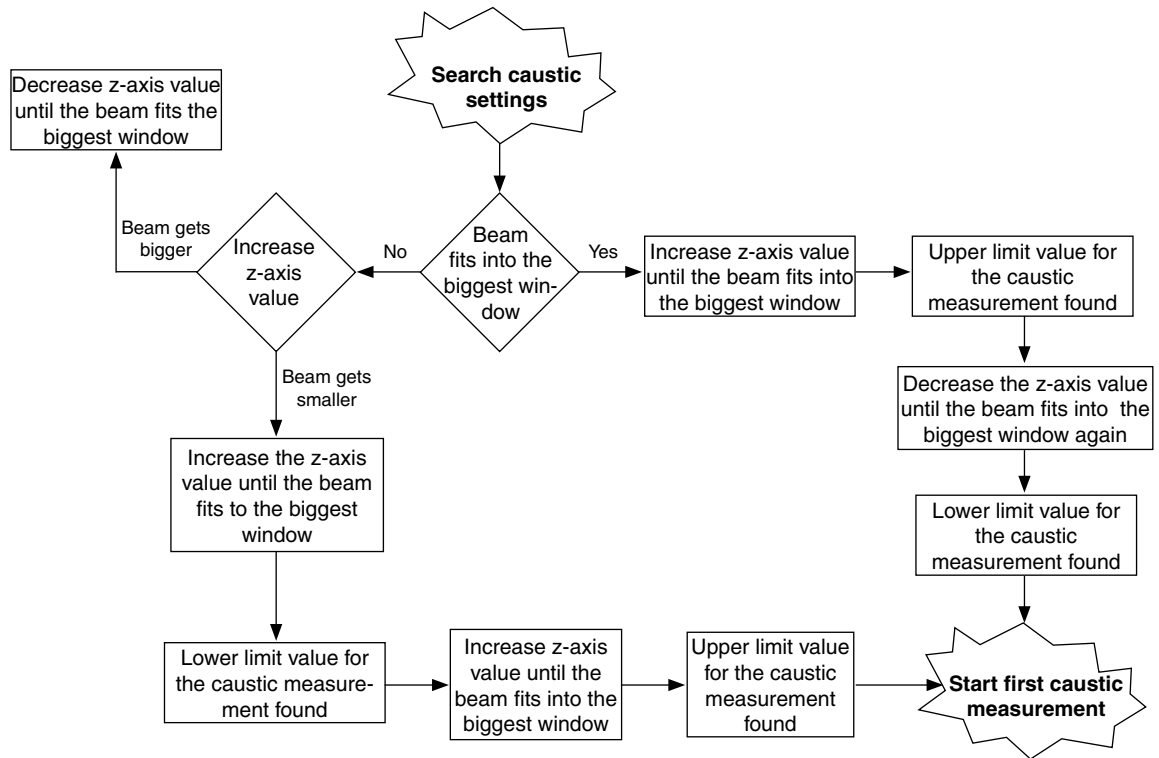

10.3.3 Plan of procedure for the first caustic measurement

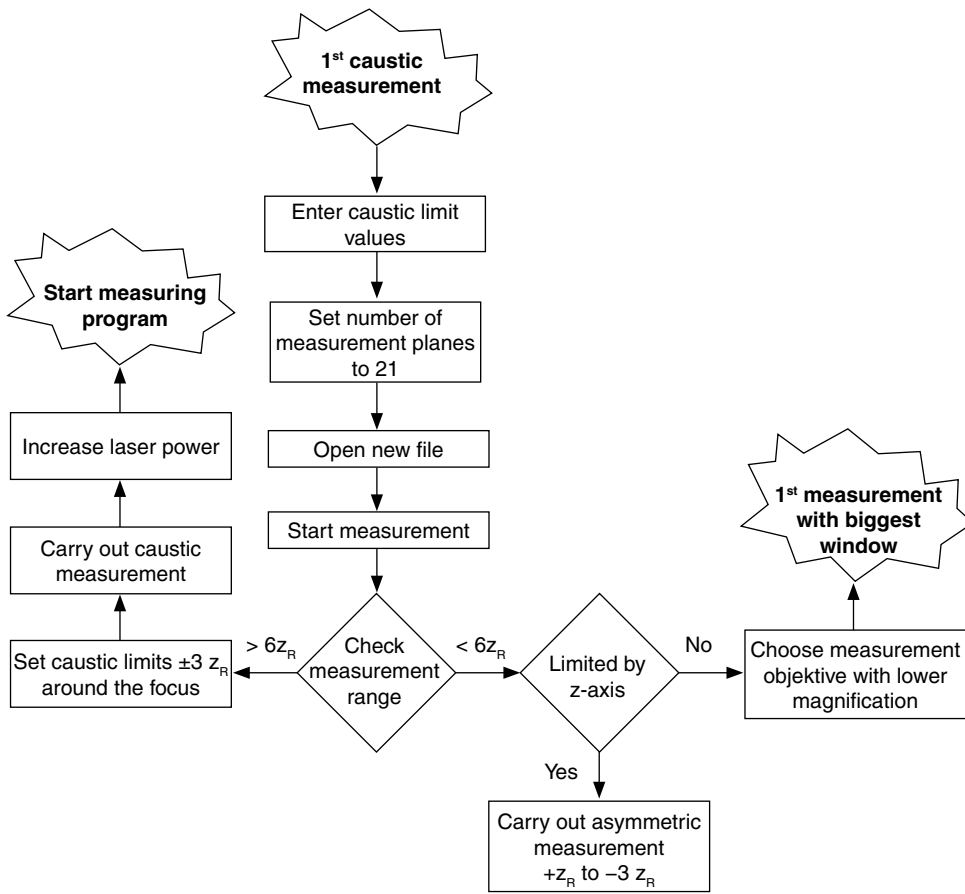

11 System Communication

For the remote control of the HP-MSM-I via the PLC interface commands and parameters have to be transferred to the HP-MSM-I and the HP-MSM-I passes information about the device status and the measurement values back to the control.

For an easy communication the HP-MSM-I contains a register bank of 1024 registers with a width of 16 bit each. These registers are used for the communication between the HP-MSM-I and the system control. In order to address the single registers 10 input lines are defined as address lines. Furthermore 16 input lines are predefined as data lines in order to write the registers. In case a writing or reading cycle is supposed to be carried out, this is displayed by means of a R/W line. A writing-/ reading cycle is initiated via the strobe line.

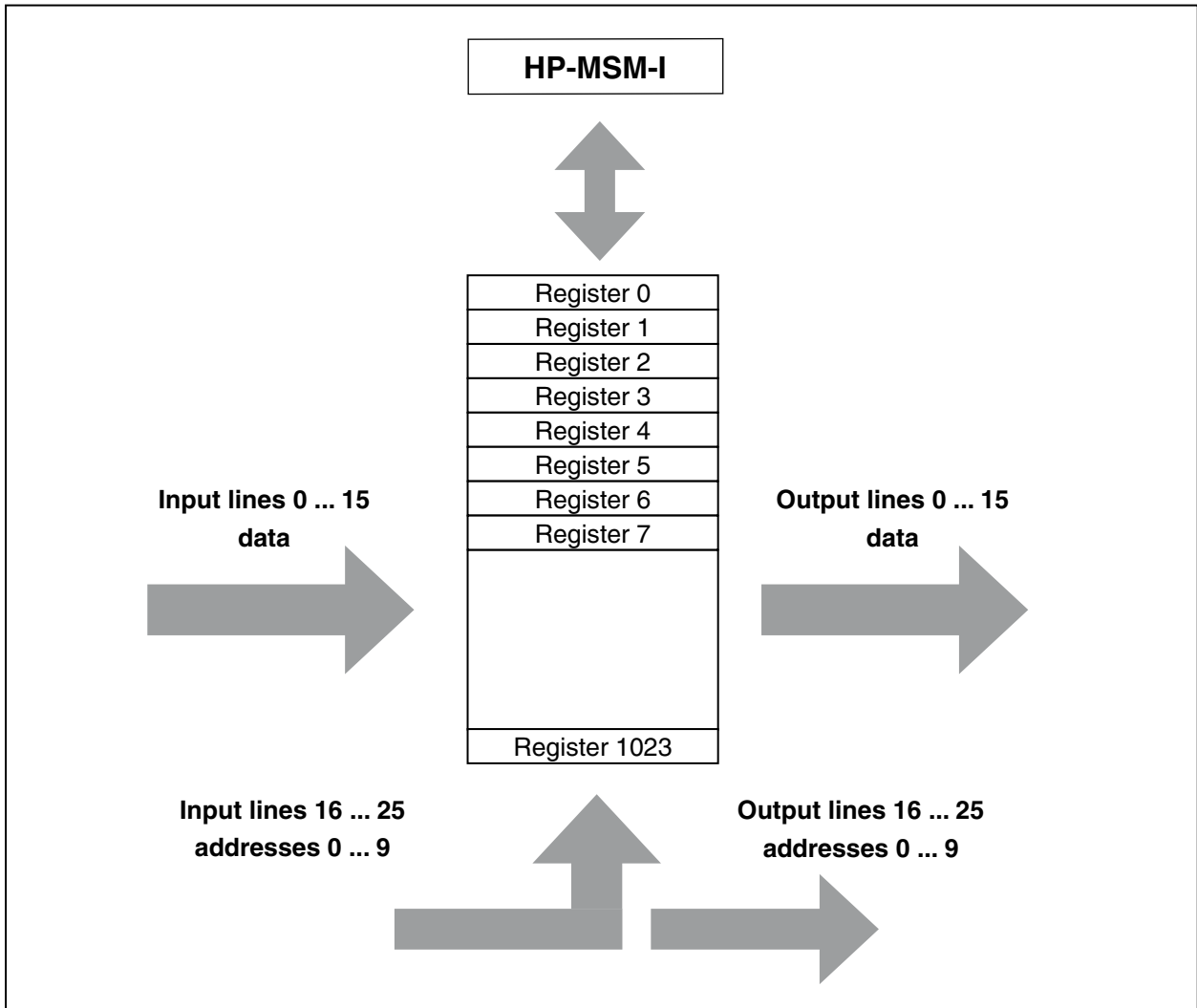

Fig.11.1: Block diagram HP-MSM-I

11.1 Operation modes

11.1.1 Read

The system wants to read an out register. Therefore, the address lines (PLC inputs) are set to the desired values with regard to the R/W lines on high level and afterwards the strobe is set to low level. The HP-MSM-I quits taking over the address and the creation of the data by setting the ack line to low level. As soon as the data was taken over, the strobe line sets them to the inactive high level. Afterwards the HP-MSM-I sets the ack line to high level again. In order to find out the device status the device can just query the registers 0 and 1.

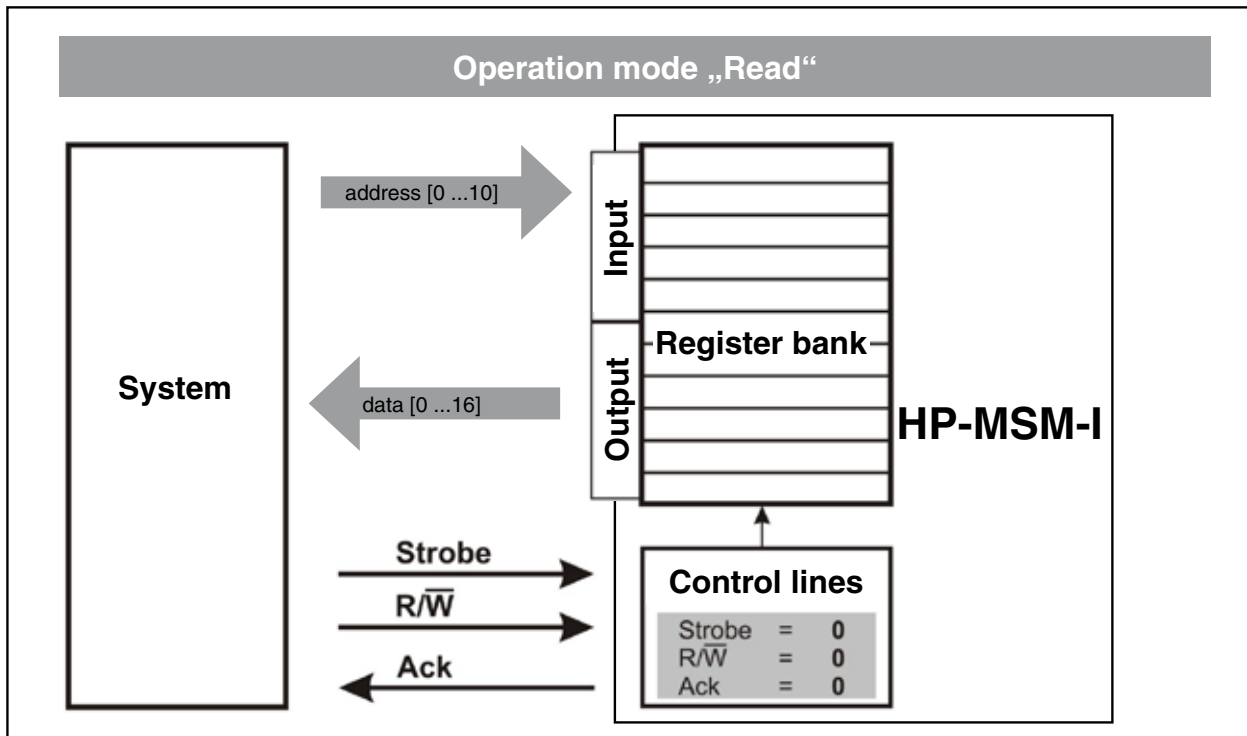

Fig.11.2: Function block diagram for the reading access for the register bank

11.1.2 Write

The system wants to write an in-register. Therefore the address- and data lines (PLC inputs) are set to the desired values with regard to the R/W line on low level and afterwards strobe is set to low level. The HP-MSM-I quits taking over the address and data by setting the ack line to low level. The system sets the strobe line to the inactive high level. Afterwards the HP-MSM-I sets the ack line to high level again.

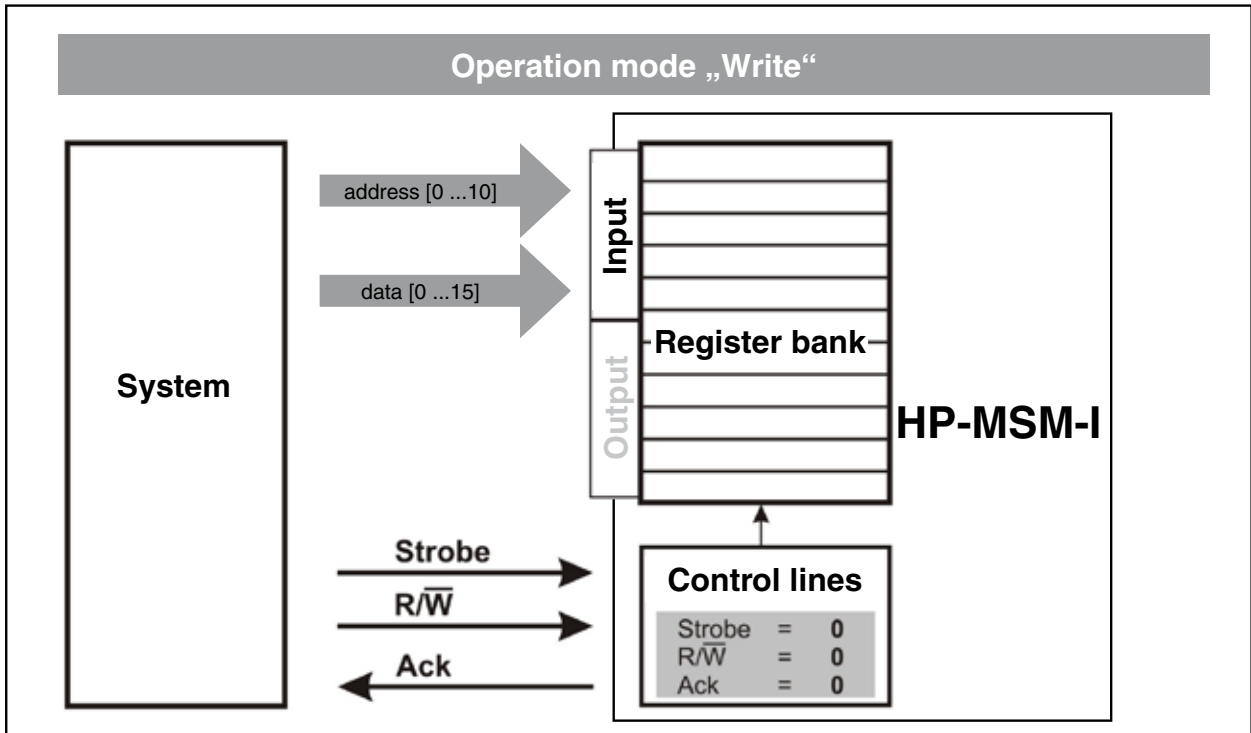

Fig.11.3: Function block diagram for the writing access for the register bank

11.1.3 Read status

As an option, the system can find out the device status by inquiring the data lines 0-25 in case of the strobe line on high level and ack line on high level.

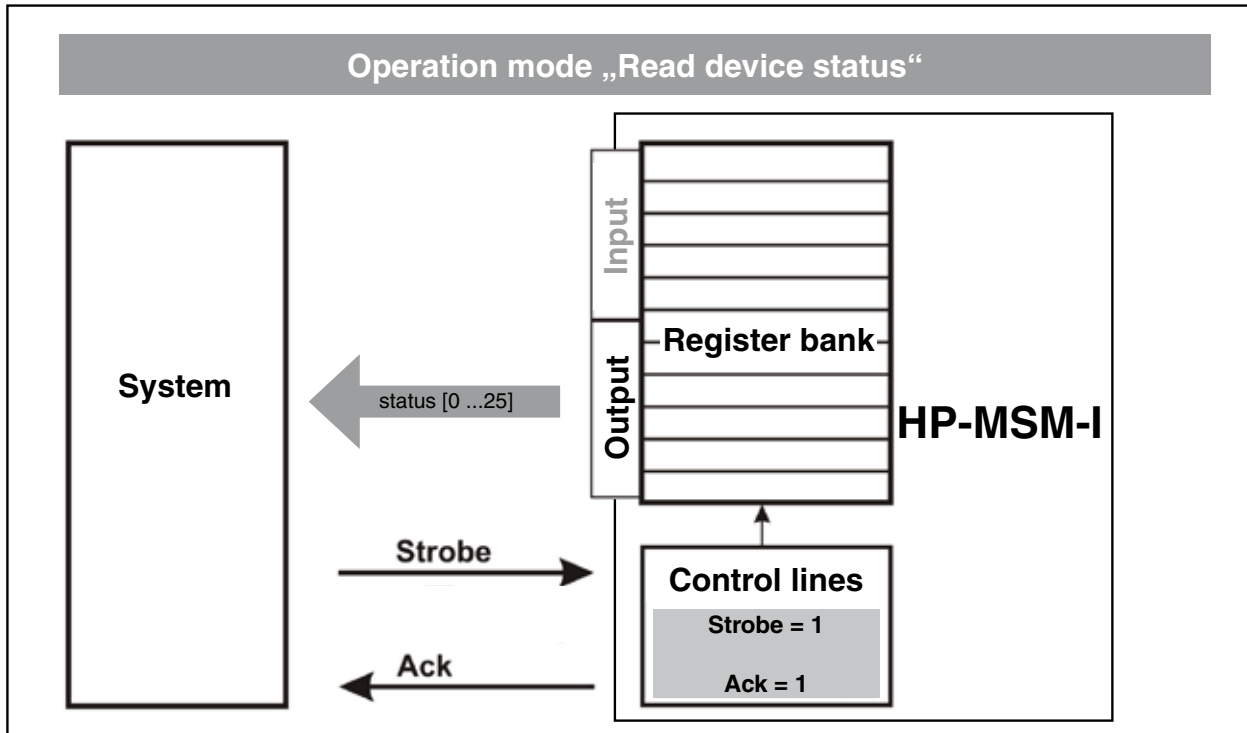

Fig.11.4: Function block diagram for the inquiry of the device status

If both the strobe-line and the ack-line are not active, information regarding the basic condition of the device are given out on the data lines.

The HP-MSM-I can read and write the register bank independently from the write-/read cycle of the system. Typically, the single registers are only writable from one side, i.e. either from the system or from the HP-MSM-I.

The data in the register bank can be read at any time, also during running measurements.

11.2 Functions of the input or output lines

The 6 more significant lines are stipulated as control lines with regard to their function. Depending on the condition, they regulate the function of the 26 less significant lines or they have a different special function. These 6 more significant lines do not have a double assignment but they continually keep their functions.

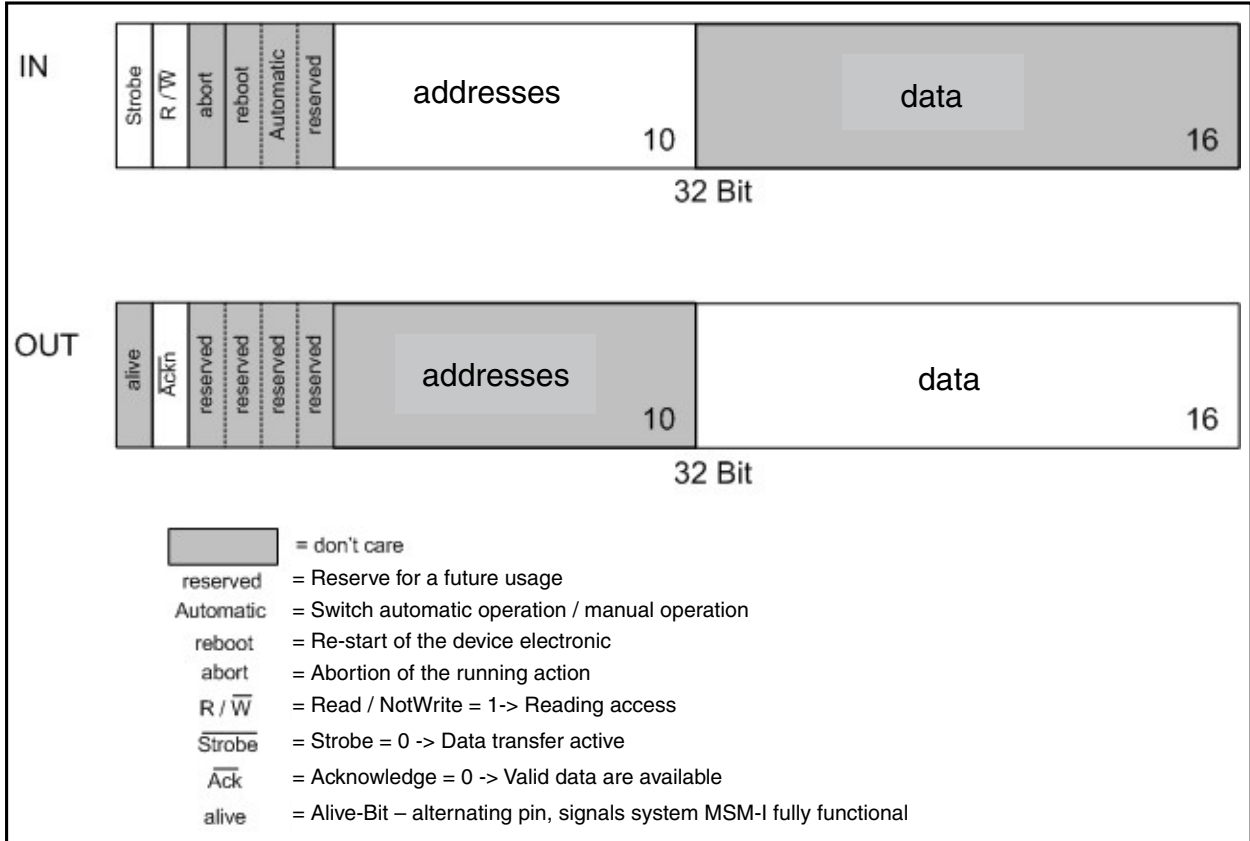

Fig.11.5: Assignment of the lines for the reading access

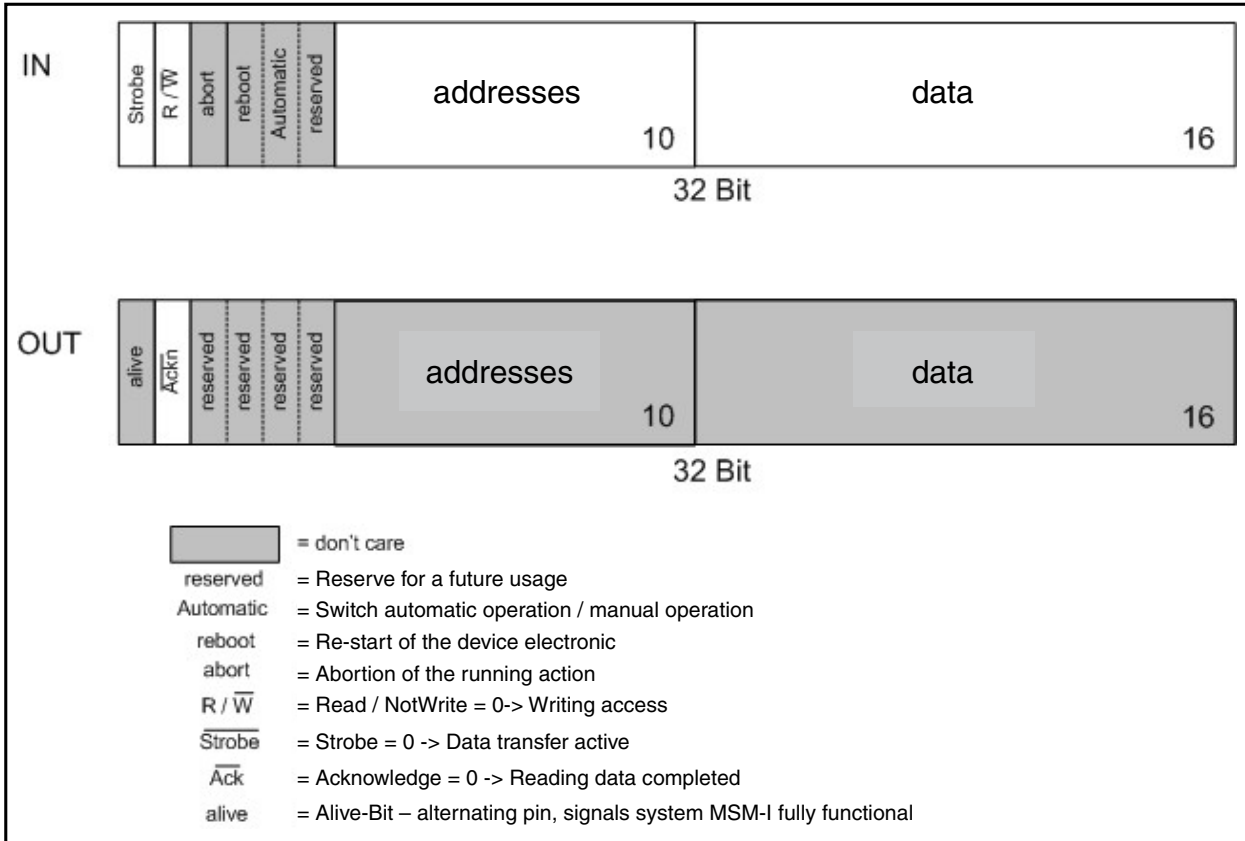

Fig.11.6: Assignment of the lines for the writing access

The 26 less significant output lines have a double assignment. These lines can not only be address- or data lines for the data transfer but they can also issue the register content of status1 with the 16 less significant lines and the register content of status2 with the 10 more significant lines.

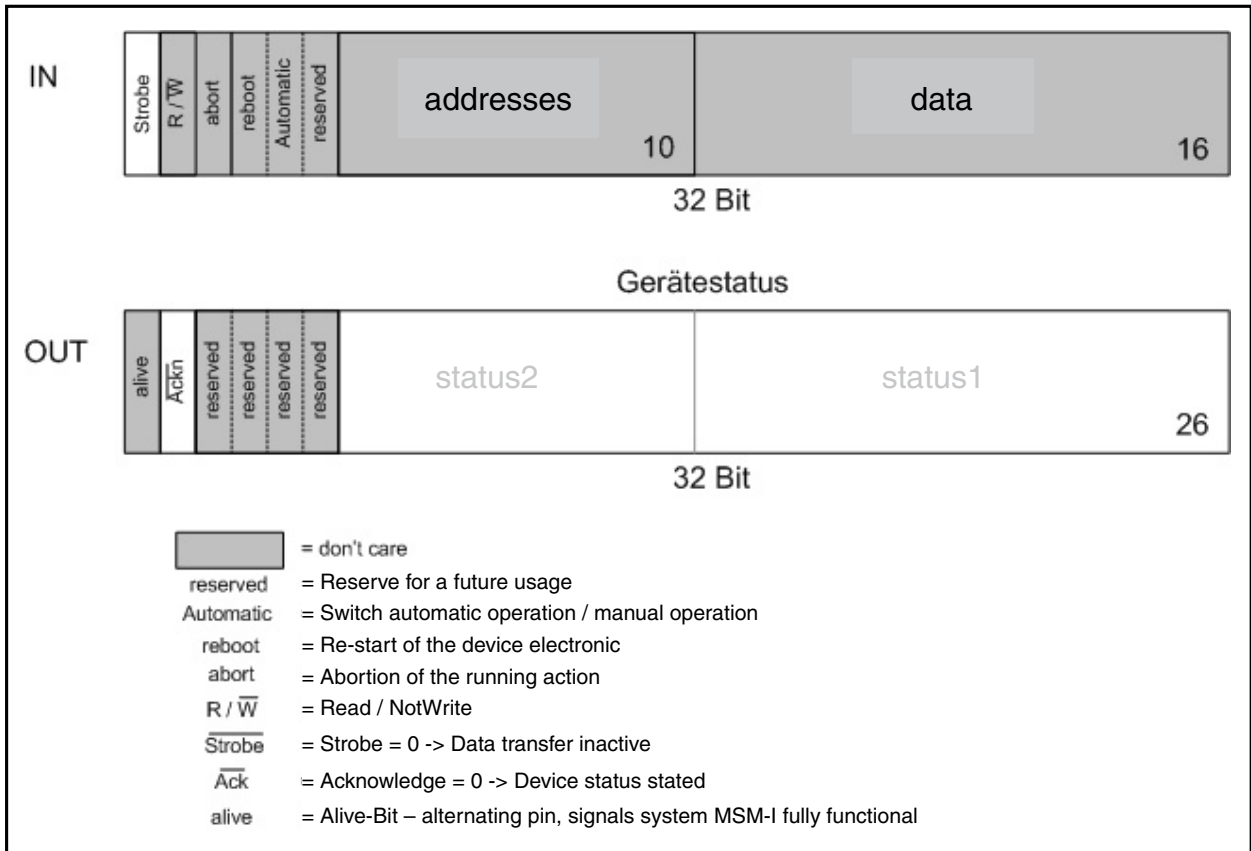

Fig.11.7: Assignment of the lines for the inquiry of the device status

11.3 Register index

Address	Mode	Sign	Register	Short description	Page	
0	0x0000	R	Flag	Status1	General condition of the device.	114
1	0x0001	R	Flag	Status2	Device condition: Warnings and errors at and in the device.	115
2	0x0002	R	Flag	PwrPreSel	Power pre-selection.	116
3	0x0003	R	Flag	WarnTFO_Reg	Warnings with regard to the internal temperatures, media, optical loads.	117
4	0x0004	R	Flag	WarnLDS_Reg	Warnings from the LaserDiagnosticsSoftware.	118
5	0x0005	R	Flag	ErrTFO_Reg	Errors with regard to the internal temperatures, media, optical loads.	119
6	0x0006	R	Flag	ErrMOE_Reg	Errors with regard to the mechanics, optics or the electronic components.	120
7	0x0007	R	Flag	ErrLDS_Reg	Errors from the LaserDiagnosticsSoftware.	121
8	0x0008	R	unsigned	ResProtect-Glass	Result register of the protective window test, conditions of the protective windows.	122
9	0x0009	R	unsigned	ResFibTst	Result of the fiber self-test.	123
10	0x000A	R	unsigned	ResFstMeas	Result of the fast measurement.	123
11	0x000B	R	unsigned	ResExtMeas	Result of the extensive measurement.	
12	0x000C	R	unsigned	ResLngMeas	Result of the long-term measurement	
13	0x000D	R	unsigned	PosX_Reg	Pre-selection for x –positioning of the laser beam for the process input.	
14	0x000E	R	signed	PosY_Reg	Pre-selection for y-positioning of the laser beam for the process input.	
15	0x000F	R	signed	PosZ_Reg	Pre-selection for z-positioning of the laser beam for the process input.	
16	0x0010	R	signed	MaxOptLoad	Maximum permissible laser power regarding the optical load.	124
17	0x0011	R	signed	EICalDev	Deviation of the EC power measurement carried out last.	
18	0x0012	R	signed	PwrPro	Mean laser power at the process input [W].	
19	0x0013	R	signed	PwrFib	Mean laser power at the fiber input [W].	124
20	0x0014	R	unsigned	FocRad	Fokus radius [µm]	
21	0x0015	R	unsigned	FocRadX	Fokus radius X-direction [µm]	
22	0x0016	R	unsigned	FocRadY	Fokus radius Y-direction [µm]	
23	0x0017	R	signed	FocPosX	Fokus position X-direction [µm]	
24	0x0018	R	signed	FocPosY	Fokus position Y-direction [µm]	
25	0x0019	R	unsigned	FocPosZ	Fokus position Z-direction [1/500 mm]	
26	0x001A	R	unsigned	MSquare	M ² [1/1000]	
27	0x001B	R	unsigned	MSquareX	M ² multiplies x-direction [1/1000]	
28	0x001C	R	unsigned	MSquareY	M ² multiplies y-direction [1/1000]	
29	0x001D	R	signed	BeamDirX	Beam angle referring to x-direction [1/1000 * mrad]	
30	0x001E	R	signed	BeamDirY	Beam angle referring to y-direction [1/1000 * mrad]	

Tab.11.1: Register index

Address		Mode	Sign	Register	Short description	Page
20	0x0014	R	unsigned	FocRad	Fokus radius [μm]	124
21	0x0015	R	unsigned	FocRadX	Focus radius X-direction [μm]	
22	0x0016	R	unsigned	FocRadY	Fokus radius Y-direction [μm]	
23	0x0017	R	signed	FocPosX	Fokus position X-direction [μm]	
24	0x0018	R	signed	FocPosY	Fokus position Y-direction [μm]	
25	0x0019	R	unsigned	FocPosZ	Fokus position Z-direction [1/500 mm]	
26	0x001A	R	unsigned	MSquare	M^2 [1/1000]	
27	0x001B	R	unsigned	MSquareX	M^2 multiplies X-direction [1/1000]	
28	0x001C	R	unsigned	MSquareY	M^2 multiplies Y-direction [1/1000]	
29	0x001D	R	signed	BeamDirX	Beam angle referring to X-direction [1/1000 * mrad]	
30	0x001E	R	signed	BeamDirY	Beam angle referring to y-direction [1/1000 * mrad]	
31	0x001F	R	unsigned	BeamParam-Prod	Beam parameter product [1/1000 * μm * mrad]	
32	0x0020	R	unsigned	Deviation	Standard deviation [1/1000 * %]	
33	0x0021	R	unsigned	Rayleigh	Rayleigh length [1/500 mm]	
34	0x0022	R	unsigned	Divergence	Divergence [1/50 * mrad]	
62	0x003E	R	Flag	Cmd1_Run	Activity register 1 points out which command is just being	125
63	0x003F	R	Flag	Cmd2_Run	Activity register 2 (currently no usage)	125
64	0x0040	R / W	Flag	Cmd1	Command register 1. Commands and messages to the HP-MSM-I.	127
65	0x0041	R / W	Flag	Cmd2	Command register 2 (currently no usage)	127
66	0x0042	R / W	Flag	Select	Selection register for the pre-setting of the different	128
67	0x0043	R / W	unsigned	Test	Test register for the function control of the system communication.	128

Register index (continuation)

11.4 Register description (reading access)

Numerous registers of the HP-MSM-I are exclusively designed for reading access. A writing access from the system is not possible.

11.4.1 Status register 1 (Status1)

Address 00000

The status register 1 includes basic status information via the device and the running measurement.

R	0	ScrpRun	LasON	ConfReq	ConfErr	WOK	OptLoad	MirFib	MirPro	SCL	SOP	MOK	MErr	MDone	MFail	MStnby
W	Status1															

Data field (value)	Description
0 - MStnby(1)	Measuring Standby – Measurement release for one of the two diagnostics Inputs selected before.
1 - MFail(2)	Measuring Failed – Status message after the completion of the measurement. An error has occurred during the measurement.
2 - MDone(4)	Measuring Done – Status message after the completion of the measurement. No error has occurred during the measurement.
3 - MErr(8)	Measuring Error – Status message after the completion of the measurement. An error has occurred in the standard evaluation. (This does not refer to the evaluation light).
4 - MOK(16)	Measuring OK – Status message after completion of the measurement. The result of the standard evaluation is ok. (This does not refer to the evaluation light).
5 - SOP(32)	Shutter Open – The shutter of the process input is open.
6 - SCL(64)	Shutter Closed – The shutter of the process input is closed.
7 - MirPro(128)	Mirror Process – The beam switch is directed to the process input.
8 - MirFib(256)	Mirror Fibre – The beam switch is directed to the fiber input.
9 - OptLoad(512)	Optical Load – Optical load is marginal. The distributed loads in the beam input is marginal in case of at least one optical surface. (This is only valid after the completion of the measurement)
10 - WOK(1024)	Water OK – Condition message EC-PM. Water flow rate and inlet temperature are within the permissible range).
11 - ConfErr(2048)	Confirmation Key Error – Error concerning the confirmation button has occurred. This flag is irrelevant for the automatic operating mode.
12 - ConfReq(4096)	Confirmation Key Request – Inquiry confirmation button. In the manual operating mode the confirmation button is necessary for the desired action. This flag is irrelevant for the automatic operating mode.
13 - LasON(8192)	Laser on – Instruction for the system to switch on the laser
14 - ScrpRun(16384)	Script running – Signals the system that the script is running and that the HP-MSM-I is now running in the automatic operating mode. An automatic measuring procedure is now possible.

Tab.11.2: Data field description status register 1 (Status1)

11.4.2 Status register 2 (Status2)

The status register 2 contains status information regarding warnings and errors occurred during the measurement operation. The flags in this register only signal the appearance of a warning or an error. For a detailed specification the respective register has to be read.

Address 00001

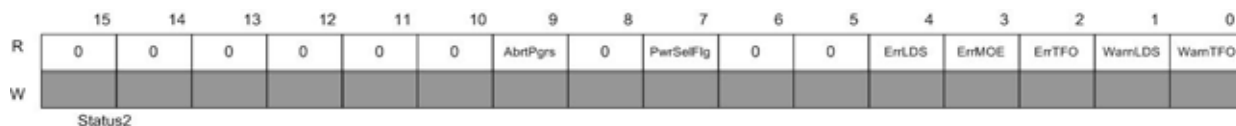

Data field (value)	Description
0 - WarnTFO(1)	Warning Temperature, Fluids, Optics – This flag signals a warning regarding the internal temperatures, warnings regarding water- and air supply and warnings in the range of the optics built in the device. Further information regarding warnings occurred can be found in the register “WarnTFO_Reg”.
1 - WarnLDS(2)	Warning LaserDiagnoseSoftware – This flag signals the warning of the LaserDiagnosticsSoftware. Further information on the warning occurred are to be read in the register “WarnLDS_Reg”.
2 - ErrTFO(4)	Error Temperature, Fluids, optical Load – This flag signals the Appearance of a warning regarding the internal temperature, errors regarding water and air supply or a problematic optical load. Further information on the errors occurred can be found in the register “ErrTFO_Reg”.
3 - ErrMOE(8)	Error Mechanics, Optics, Electronic – This flag signals an error of the mechanical components regarding errors in the range of internal optics or the electronic components. Further information on the errors occurred can be found in the register “ErrMOE_Reg”.
4 - ErrLDS(16)	Error LaserDiagnoseSoftware – This flag signals an error of the LaserDiagnosticsSoftware. Further information on the errors occurred can be found in the register “ErrLDS_Reg”.
7 - PwrSelFlg(128)	Power Select Flag – This flag refers to the new power pre-selection from the HP-MSM-I.
9 - AbtPgrs(512)	Abort in Progress – This status bit points out that the current measurement procedure is cancelled.

Tab.11.3: Data field description status register (Status2)

11.4.3 Power Pre-Selection (PwrPreSel_Reg)

In the power pre-selection register the HP-MSM-I indicates which power from the laser system is needed for the forthcoming measurement.

Address 00002

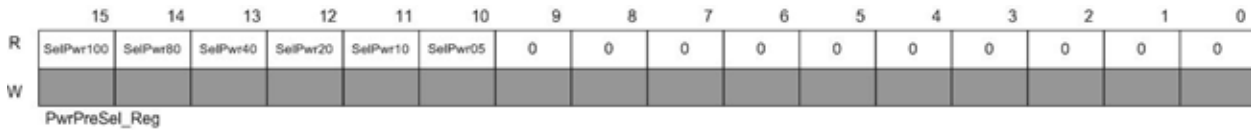

Data field (value)	Description
10 - SelPwr05(1024)	Select Power 05 – For the forthcoming measurement 5 % of the maximum laser power are requested by the system.
11 - SelPwr10(2048)	Select Power 10 – For the forthcoming measurement 10 % of the maximum laser power are requested by the system.
12 - SelPwr20(4096)	Select Power 20 – For the forthcoming measurement 20 % of the maximum laser power are requested by the system.
13 - SelPwr40(8192)	Select Power 40 – For the forthcoming measurement 40 % of the maximum laser power are requested by the system.
14 - SelPwr80(16384)	Select Power 80 – For the forthcoming measurement 80 % of the maximum laser power are requested by the system.

Tab.11.4: Data field description Power Pre-Selection

11.4.4 Warning Flag Register Temperature, Media, Optics (WarnTFO_Reg)

In the warning flag register for temperatures, media and the optical elements the respective warnings are specified in detail.

Address 00003

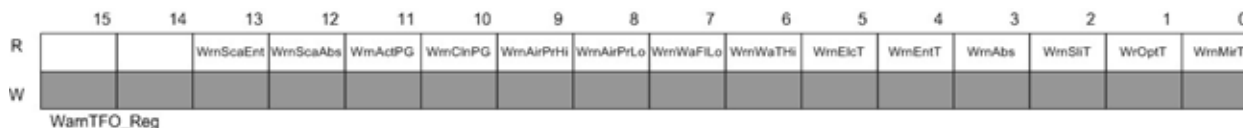

Data field (value)	Description
0 - WrnMirT(1)	Warning: Mirror Temperature – Temperature at the switch fiber , or – respectively – process beam measurement lies above the warning threshold.
1 - WrnOptT(2)	Warning: Optic Temperature – Temperature in the optical system lies above the warning threshold.
2 - WrnSlitT(4)	Warning: Slide Temperature – Temperature in the range of the z-axis lies above the warning threshold.
3 - WrnAbsT(8)	Warning: Absorber Temperature – Temperature in the absorber lies above the warning threshold.
4 - WrnEntT(16)	Warning: Entrance Temperature – Temperature in the entrance block lies above the warning threshold.
5 - WrnElcT(32)	Warning: Electronic Temperature – Temperature in the range of the electronics lies above the warning threshold.
6 - WrnWaThHi(64)	Warning: Water Temperature High – Cooling water temperature is less than 20 % away from the interlock-relevant error limit.
7 - WrnWaFloLo(128)	Warning: Water Flow Low – Flow rate cooling water is less than 20 % away from the interlock-relevant error limit.
8 - WrnAirPrLo(256)	Warning: Air Pressure Low – Difference value of the current air pressure is less than 20 % away from the interlock-relevant lower error limit.
9 - WrnAirPrHi(512)	Warning: Air Pressure High – Difference value of the current air pressure is less than 20 % away from the interlock-relevant upper error limit.
10 - WrnClnPG(1024)	Warning: Clean Protection Glass – Only one clean, tested protective window is left in the protective window exchanger. The remaining protective windows are either contaminated or not tested.
11 - WrnActPG(2048)	Warning: Actual Protection Glass – Currently a contaminated or untested protective window is positioned in the measuring position.
12 - WrnScaAbs(4096)	Warning: Scatterlight Absorber – Scattered light at the absorber has almost reached the limit value.
13 - WrnScaEnt(8192)	Warning: Scatterlight Entrance – Scattered light in the entrance block has almost reached the limit value.

Tab.11.5: Data field description Warning Flag Register Temperatures, Media, Optics

11.4.5 Warning Flag Register LaserDiagnosticsSoftware (WarnLDS_Reg)

In the warning flag register for warning messages of the LaserDiagnosticsSoftware the respective warnings are specified in detail. (Currently these warning flags are no longer specified.)

Address 00004

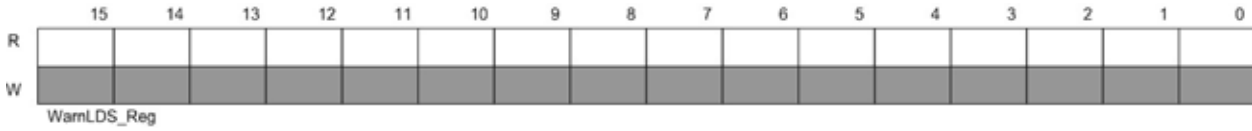

Data field	Description
15:0 WarnLDS[15:0]	There are warnings from the LaserDiagnosticsSoftware depending from the flags set.

Tab.11.6: Data field description Warning Flag Register LaserDiagnosticsSoftware

11.4.6 Error Flag Register Temperatures, Media, Optics (ErrTFO_Reg)

In the error flag register for temperatures, media and the optical elements warnings are specified in detail.

Address 00005

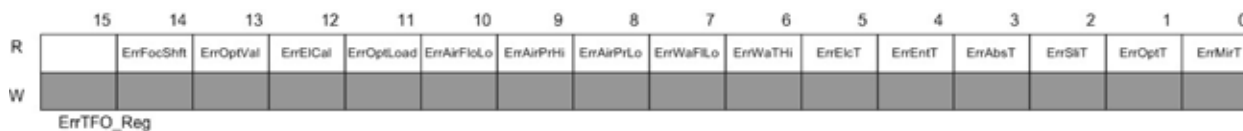

Data field (value)	Description
0 - ErrMirT(1)	Error: Mirror Temperature – Temperature at the switch fiber or – respectively process beam measurement lies above the interlock-relevant error threshold.
1 - ErrOptT(2)	Error: Optics Temperature – Temperature in the optical system lies above the interlock-relevant error threshold.
2 - ErrSlit(4)	Error: Slide Temperature – Temperature in the range of the z-axis lies above the interlock-relevant error threshold.
3 - ErrAbsT(8)	Error: Absorber Temperature – Temperature in the absorber lies above the interlock-relevant error threshold.
4 - ErrEntT(16)	Error: Entrance Temperature – Temperature in the entrance block lies above the interlock-relevant error threshold.
5 - ErrElcT(32)	Error Electronic Temperature – Temperature in the range of the electronics temperature lies above the interlock relevant error threshold.
6 - ErrWaTHi(64)	Error: Water Temperature High – Outlet temperature of the cooling water is too high (interlock-relevant).
7 - ErrWaFILO(128)	Error: Water Flow Low – Water flow rate cooling water is too low (interlock-relevant, limit value 4 l/min).
8 - ErrAirPrLo(256)	Error: Air Pressure Low – Air pressure too low (interlock-relevant).
9 - ErrAirPrHi(512)	Error: Air Pressure High – Air pressure too high (interlock-relevant).
10 - ErrAirFloLo(1024)	Error: Air Flow Low – Air flow is too low.
11 - ErrOptLoad(2048)	Error: Optical Load – Optical load above the limit values.
12 - ErrEICal(4096)	Error: Electrical Calibration – Result of the last EC-calibration is defective or not carried out.
13 - ErrOptVal(8192)	Error: Optical Validation – Result of the last optical validation (protective window test) is defective or not carried out.

Tab.11.7: Data field description Error Flag Register Temperatures, Media, Optics

11.4.7 Error Flag Register Mechanics, Optics, Electronics (ErrMOE_Reg)

In the error flag register for mechanics, optics and electronics warnings are specified in detail.

Address 00006

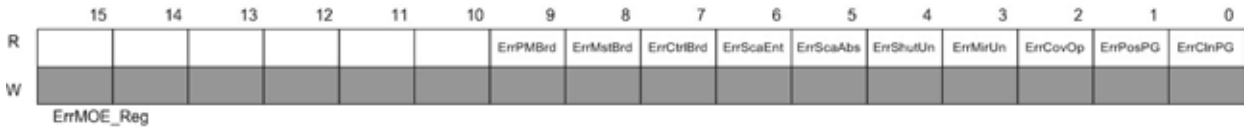

Data field (value)	Description
0 - ErrClnPG(1)	Error: Clean ProtectionGlass – All protective windows are contaminated or untested.
1 - ErrPosPG(2)	Error: Position ProtectionGlass – Position of the protective window exchanger undefined or unknown (interlock-relevant).
2 - ErrCovOp(4)	Error: Cover Open – Cover of the protective window exchanger is open (interlock-relevant).
3 - ErrMirUn(8)	Error: Mirror Undefined – Position of the beam switch undefined or unknown (interlock-relevant).
4 - ErrShutUn(16)	Error: Shutter Undefined – Position of the shutter undefined or unknown (interlock-relevant).
5 - ErrScaAbs(32)	Error: Scatterlight Absorber – Too much scattered light in the range of the absorber (interlock-relevant).
6 - ErrScaEnt(64)	Error: Scatterlight Entrance – Too much scattered light in the range of the entrance block (interlock relevant).
7 - ErrCtrlBrd(128)	Error: Controller Board – Severe error controller board (interlock relevant).
8 - ErrMstBrd(256)	Error: Master Board – Severe error master board (interlock-relevant).
9 - ErrPMBrd(512)	Error: Power Monitor Board – Severe error EC-PM-board (interlock-relevant).

Tab.11.8: Data field description Error Flag Register Mechanics, Optics, Electronics

11.4.8 Error Flag Register LaserDiagnosticsoftware (ErrLDS_Reg)

In the error flag register for warning messages of the LaserDiagnosticsSoftware respective warnings are specified in detail. (Currently these warning flags are not specified yet.)

Address 00007

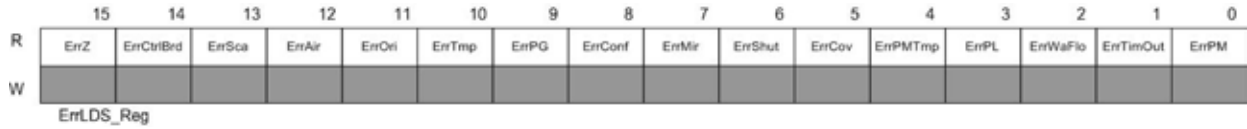

Data field (value)	Description
0 - ErrPM(1)	Error: PowerMonitor – Status of the power measurement device (PowerMonitor) is unknown.
1 - ErrTimOut(2)	Error: Time Out – Time control function for actions which are to be carried out has reacted.
2 - ErrWaFlo(4)	Error: Water Flow – Water flow rate is too low.
3 - ErrPL(8)	Error: Power Laser – Power values calculated by the PowerMonitor are too high for the action which is to be carried out.
4 - ErrPMTmp(16)	Error: Power Monitor Temperature – There is a temperature error with regard to the PowerMonitor.
5 - ErrCov(32)	Error: Cover – The cover of the protective window exchanger has been opened inadmissibly.
6 - ErrShut(64)	Error: Shutter – Error has occurred concerning the opening and closing of the shutter.
7 - ErrMir(128)	Error: Mirror – Error has occurred concerning the adjustment of the fiber mirror. Fiber mirror in an inadmissible position.
8 - ErrConf(256)	Error: Confirmation Key – Error has occurred concerning the confirmation key. Confirmation key was activated inadmissibly or not at the right moment.
9 - ErrPG(512)	Error: Protection Glass – Error has occurred concerning the protective window.
10 - ErrTmp(1024)	Error: Temperature – Error has occurred concerning the temperature.
11 - ErrOri(2048)	Error: Orientation – Error has occurred concerning the position sensors. Inadmissible position of the device.
12 - ErrAir(4096)	Error: Air – Error has occurred concerning the air flow or the air pressure values.
13 - ErrSca(8192)	Error: Scatterlight – Scattered light values too high.
14 - ErrCtrlBrd(16384)	Error: Controller-Board – Error has occurred concerning the Controller Board or a missing feedback controller board.
15 - ErrZ(32768)	Error: Z-Axis – Error has occurred concerning the movement of the z-axis.

Tab.11.9: Data field description Error Flag Register LaserDiagnosticsSoftware

11.4.9 Result Register Protective Window Test (ResProtectGlass)

The flags in the result register provide information regarding the condition of the protective windows. The condition of the protective windows (clean, contaminated, untested) is inquired via the flags.

Address 00008

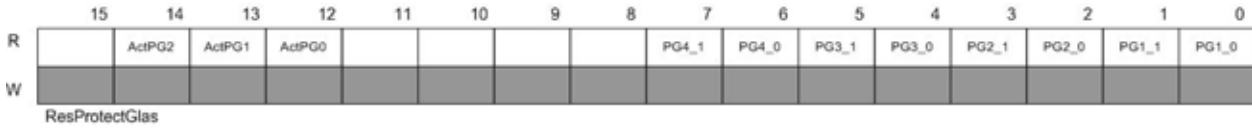

Data field	Description
1:0 PG1[1:0]	Protection Glass 1 – Condition protective window 1.
3:2 PG2[1:0]	Protection Glass 2 – Condition protective window 2.
5:4 PG3[1:0]	Protection Glass 3 – Condition protective window 3.
7:6 PG4[1:0]	Protection Glass 4 – Condition protective window 4.
14:12 ActPG[2:0]	Actual Protection Glass – Number of the current protective window.

Tab.11.10: Data field description Result Register Protective Window Test

Condition flags of the protective windows and their meaning:

Condition	PG1 [1:0]	PG2 [1:0]	PG3 [1:0]	PG4 [1:0]
Protective window untested	00	00	00	00
Protective window tested, not ok	01	01	01	01
Protective window tested, ok	11	11	11	11
Undefined	10	10	10	10

Position of the current protective window:

Current protective window	ActPG [2:0]
Protective window 1 is in position	001
Protective window 2 is in position	010
Protective window 3 is in position	011
Protective window 4 is in position	100
Error: No protective window in position	000

11.4.10 Value register

All registers listed in the following table are value registers in the following format:

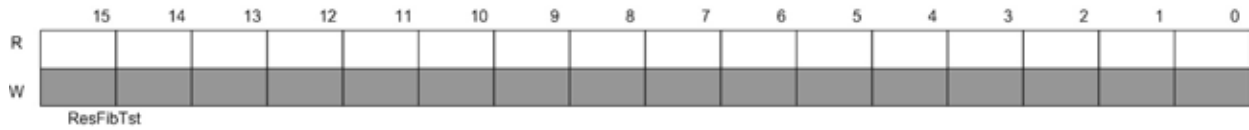

Data field	Description
15:0 Name[15:0]	

Address	Function (name)	Description
00009	Fiber self-test (ResFibTst)	In case of nOK measurements and after the request from the control a test of an internal protective window is carried out. Therefore the laser beam is requested via the replacement fiber and a focus caustic is measured. These results are compared with reference data. In case of an nOK condition of the protective window the next clean protective window is approached and the test is repeated. If then an OK measurement is detected, the beam test can be repeated. If an nOK measurement is detected, a maintenance is recommended. If all protective windows are nOK an exchange of the protective windows are recommended (duration for a run 120 s, several runs possible).
00010	Fast measurement (ResFstMeas)	Control of the focus caustic for process performance at few measurement planes as well as power measurement. This measurement can be initiated within a few machine strokes (6 s). The results are stored and compared with reference data. Status information as well as important measurement values are reported back to the system (duration: 50 s).
00011	Detailed measurement (ResExtMeas)	Measurement of the focus caustic for process performance at typically 21 measurement planes. Duration of the measurement 2 to 3 minutes. The results are stored and compared with reference data. Status information as well as important measurement values are reported back to the system (duration: 120 s).
00012	Long-term measurement (ResLngMeas)	Measurement of the beam radius at the focus position over a longer period of time (duration: 10 min).
00013	(PosX_Reg)	The value in this register is in accordance with the deviation of the laser spots in x-direction with regard to the measuring window.
00014	(PosY_Reg)	The value in this register is in accordance with the deviation of the laser spots in y-direction with regard to the measuring window.
00015	(PosZ_Reg)	The value in this register is in accordance with the deviation of the laser spots in z-direction with regard to the measuring window.
00016	Maximum optical load (MaxOptLoad)	Inquiry of the last value regarding the maximum laser power for the highest admissible optical load. This value is based on the measurement carried out last.
00017	Deviation elect. Calibration (EICalDev)	Result of the last EC-calibration. By means of this, a deviation of the calorimetric power measuring part can be transmitted to the system.

Address	Function (name)	Description
00018	Laser power process input (PwrPro)	Result of the last power measurement at the process input.
00019	Laser power fiber input (PwrFib)	Result of the last power measurement at the fiber input.
00020	Fokus radius (FocRad)	Combined focus radius of the last caustic measurement.
00021	Focus radius in x-direction (FocRadX)	Focus radius in x-direction of the last caustic measurement.
00022	Focus radius in y-direction (FocRadY)	Focus radius in y-direction of the last caustic measurement.
00023	Focus position in x-direction (FocPosX)	Position of the beam center of the focus of the last caustic measurement referring to the center of the measurement range in x-direction.
00024	Focus position in y-direction (FocPosY)	Position of the beam center of the focus of the last caustic measurement referring to the center of the measurement range in y-direction.
00025	Focus position in z-direction (FocPosZ)	Position of the focus of the last caustic measurement along the spread direction referring to the zero position of the z-axis (Z = 0 mm).
00026	Diffraction index (Msquare)	Combined M^2 of the laser beam as a parameter for the beam quality of the last caustic measurement.
00027	Diffraction index in x-direction (MsquareX)	M^2 of the laser beam as a parameter for the diffraction limit in x-direction of the last caustic measurement.
00028	Diffraction index in y-direction (MsquareY)	M^2 of the laser beam as a parameter for the diffraction limit in y-direction of the last caustic measurement.
00029	Beam angle in x-direction (BeamDirX)	Indication of the beam spread direction in reference to the x-axis of the HP-MSM-I coordinate system. Indication in 1/1000 mrad.
00030	Beam angle in y-direction (BeamDirY)	Indication of the beam spread direction in reference to the y-axis of the HP-MSM-I coordinate system. Indication in 1/1000 mrad.
00031	Beam parameter product (BeamParamProd)	Beam parameter product as an index for the beam quality of the last caustic measurement. The unit is mm*mrad, the correction factor is 1000.
00032	Standard deviation (Deviation)	Standard deviation of the combined hyperbolic fit of the last caustic measurement. Indication in 1/10000 %.
00033	Rayleigh length (Rayleigh)	Index which indicates for which length the power density of the beam decreases by the factor 2. Indication in 1/500 mm.
00034	Divergence angle (Divergence)	Swelling angle of the beam which is not convergent. Indication in 1/50 mrad.

Tab.11.11: Overview value register

11.4.11 Activity register command 1 (Cmd1_Run)

The flags in this register signal the system which command is just active and processed. The register Cmd1_Run and Cmd2_Run correspond to the command registers Cmd1 and Cmd2 (please see chapter 11.5 on page 127), are, however, only readable and not writable. If a command is sent from the system to the HP-MSM-I, the respective activity flag is set in the corresponding activity register. The activity flag is not reset before

- the command initiated and the corresponding procedure is completed
- the procedure was cancelled before by means of the control line “abort”
- a “reboot” was carried out.

Address 00062

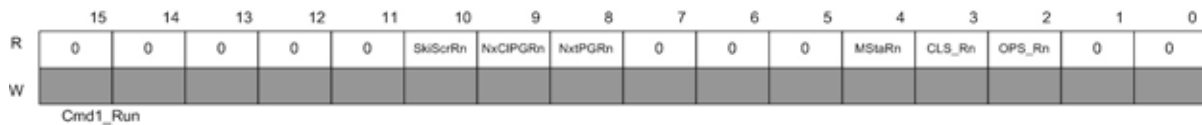

Data field (value)	Description
2 - OPS_Rn(4)	Open Shutter Running – Shutter is just opened.
3 - CLS_Rn(8)	Close Shutter Running – Shutter is just closed.
4 - MStaRn(16)	Measuring Start Running – Measurement is running.
8 - NxtPGRn(256)	Next Protection Glass Running – Protective window exchanger moves to the next protective window.
9 - NxCIPGRn(512)	Next Clean Protection Glass Running – Protective window exchanger moves to the next clean protective window.
10 - SkiScrRn(1024)	Skip Script Running – Script is completed. Device is just set to standby.

Tab.11.12: Data field description Active Register Command 1

11.4.12 Active Register Command 2 (Cmd2_Run)

Order and command register for further commands (currently not specified yet).

Address 00063

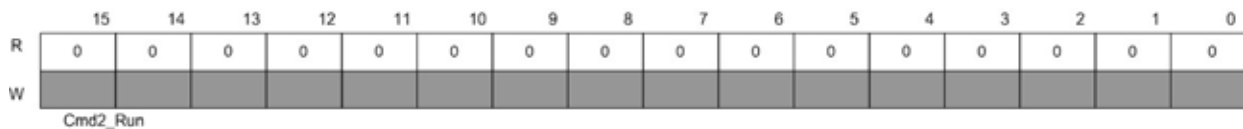

Data field	Description
15:0 Cmd2_Run[15:0]	

Tab.11.13: Data field description Activity Register Command 1

11.4.13 Chronological sequence of the register content when a command is initiated

By means of the chronological sequence depicted in Fig.11.8 it is to be made clear how a command (here in order to open the shutter) is initiated correctly to the HP-MSM-I.

The command is written into the respective register. In the example bit 2 is set in register 64 in order to open the shutter (register 00064 gets the value 4).

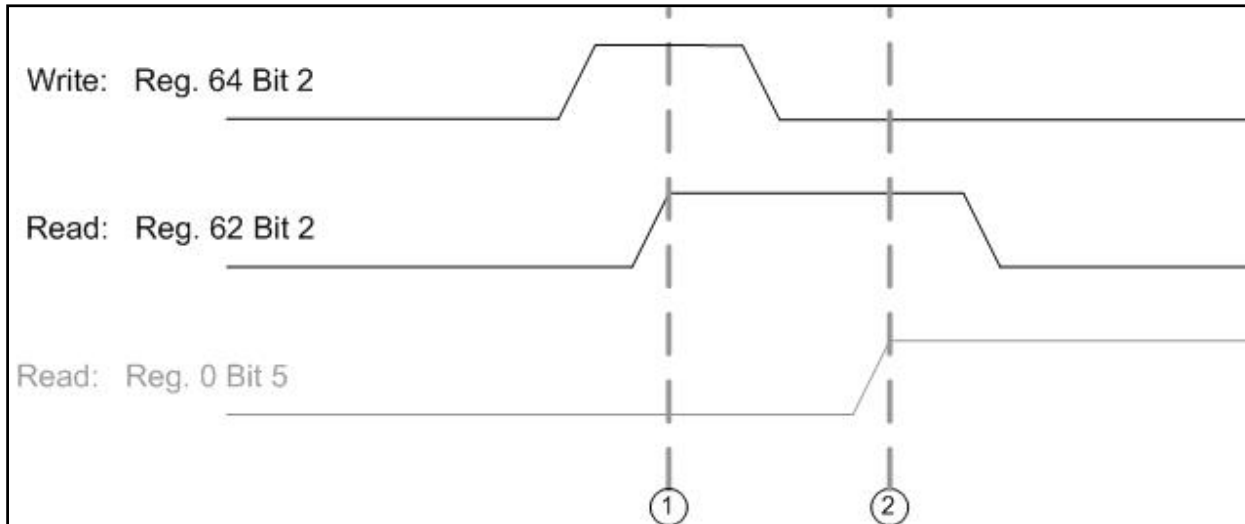

Fig.11.8: Chronological sequence of the register content when a command is initiated

①
As soon as the command has arrived this can be read in register 62 bit 2 (register 00062 has to have the value 4). In this case the command is taken back in order to prevent the multiple initiation of the same command. Therefore the register 64 is deleted (register 00064 gets the value 0). The actual command is not processed. The shutter is opened.

②
When the shutter is opened completely and the command is therefore processed, this is to be checked in register 62. Register 62 then has to have the value 0. Additionally, the status of the shutter can be read in the status register (register 00000). If the shutter was opened correctly, bit 5 is set.

11.5 Register Description (reading and writing access)

The following register of the HP-MSM-I can not only be written but also read. These registers are intended for commands and pre-settings at the HP-MSM-I.

11.5.1 Command 1 (Cmd1)

Command register for the control of the HP-MSM-I via the system. Feedback from the laser system to the HP-MSM-I can also be found in this register.

Address 00064

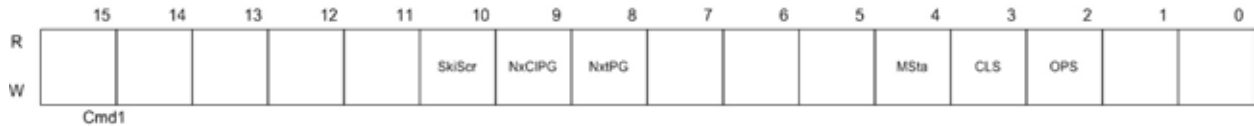

Data field (value)	Description
2 - OPS(4)	Open Shutter – Open shutter.
3 - CLS(8)	Close Shutter – Close shutter.
4 - MSta(16)	Measuring Start – Start measurement
8 - NxtPG(256)	Next Protection Glass – Approach next protective window.
9 - NxCIPG(512)	Next Clean Protection Glass – Approach next clean protective window.
10 - SkiScr(1024)	Skip Script – Cancel the script. Set device to standby-mode.

Tab.11.14: Data Field Description Command Register 1

11.5.2 Command 2 (Cmd2)

Command register for further commands (currently not specified yet).

Address 00065



Data field	Description
15:0 Cmd2[15:0]	

Tab.11.15: Data Field Description Command Register 2

11.5.3 Selection Register (Select)

In the selection register the different measurement programs as well as the power- and position pre-selections can be made.

Address 00066

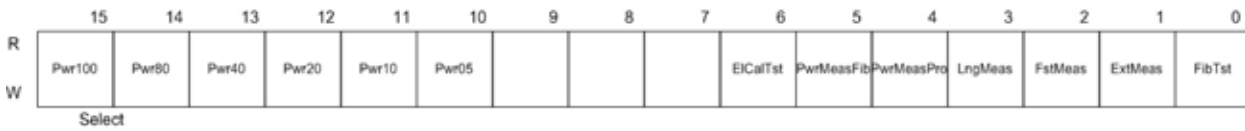

Data field	Description
0 - FibTst(1)	Fibre Test – Self-test HP-MSM-I regarding optics and protective windows. SelfTstOpt = 1: Protective window clean and optics OK.
1 - ExtMeas(2)	Extended Measuring – Extended focus measurement.
2 - FstMeas(4)	Fast Measuring – Fast focus measurement.
3 - LngMeas(8)	Long Term Measuring – Long-term measurement.
4 - PwrMeasPro(16)	Power Measuring Process – Power measurement at the process input
5 - PwrMeasFib(32)	Power Measuring Fibre – Power measurement at the fiber.
6 - EICalTst(64)	Electrically Calibration Test – Self-test power part HP-MSM-I. (EC-measurement)
10 - Pwr05(1024)	Powerselect 05 – Power pre-selection with 5 % of the maximum power.
11 - Pwr10(2048)	Powerselect 10 – Power pre-selection with 10 % of the maximum power.
12 - Pwr20(4096)	Powerselect 20 – Power pre-selection with 20 % of the maximum power.
13 - Pwr40(8192)	Powerselect 40 – Power pre-selection with 40 % of the maximum power.
14 - Pwr80(16384)	Powerselect 80 – Power pre-selection with 80 % of the maximum power.
15 - Pwr100(32768)	Powerselect 100 – Power pre-selection with 100 % of the maximum power.

Tab.11.16: Data Field Description Selection Register

11.5.4 Test Register (Test)

The test register is designed for the function control of the system communication with the HP-MSM-I. Arbitrary values can be written into this register and afterwards read out again.

For functions of the HP-MSM-I and the diverse measurement programs this register is irrelevant.

Address 00067



Data field	Description
15:0 Test[15:0]	Register for the function control of the communication between the HP-MSM-I and the system.

Tab.11.17: Data Field Description Test Register

12 Maintenance

For service, maintenance and calibration we recommend returning the HP-MSM-I to the manufacturer every 12 months.

12.1 Renew Protective Windows

Before exchanging the protective windows, the following conditions need to be fulfilled:

- The supply voltage is switched on
- The compressed air is connected with enough pressure
- The shutter is closed

In order to exchange protective windows there is a closed inspection aperture in the housing which is dust proof. After opening the inspection flap, the number of the protective window which is currently located in the exchange slot is indicated by a fast flashing of the respective LED. If desired, another protective window can be positioned in the exchange slot by means of the button “Next Protective Window” (please also see chapter „4.5 Display“ on page 15).

The glass mounting of the protective window is held in the exchange slot by means of three spring loaded balls. By means of the supplied mounting handle the protective window can be pulled out against the spring pressure vertically upwards. It can be put in again in the same way.

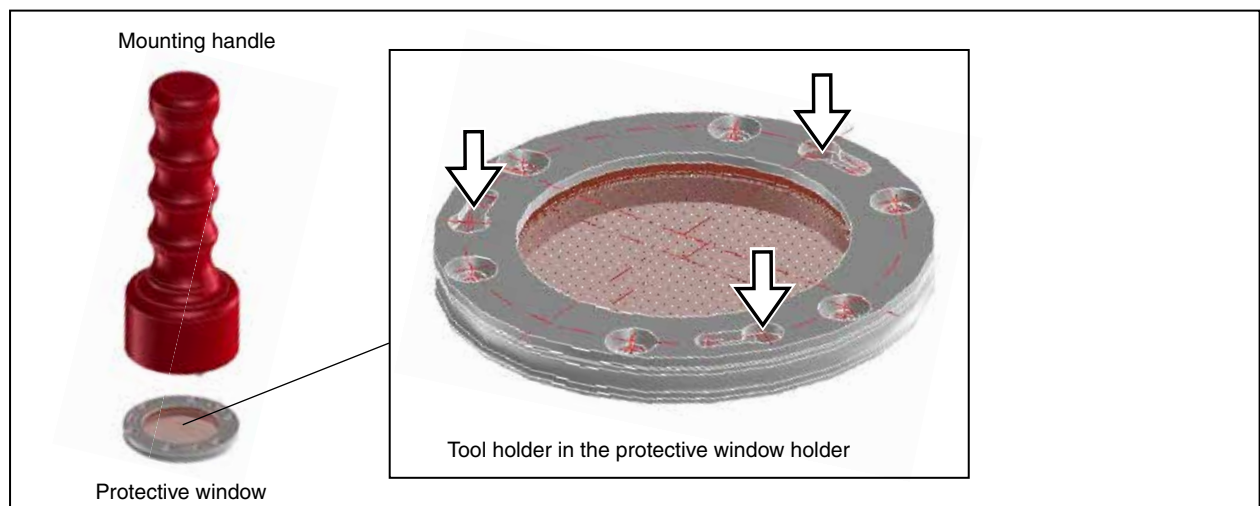

Fig.12.1: Mounting handle for the protective window exchange

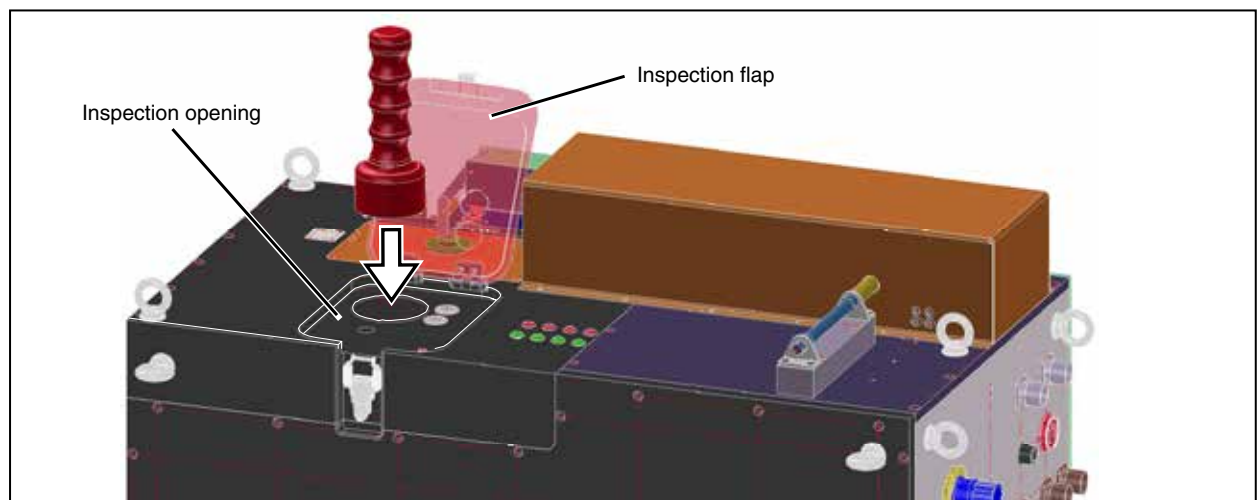

Fig.12.2: Putting in the mounting handle

Removing the protective window

1. Open the inspection flap.
2. If needed, press key 1 "Next Protective Window" (please see Fig.12.3) until the desired protective window is positioned (the respective LED flashes fast).
3. Put the mushroom counter pins of the mounting handle into the respective opening of the glass mounting and turn the handle clock-wise by approx. 15 degrees.
4. Pull out the protective window out of the exchange slot vertically upwards.

Putting in the protective window

1. Install the new protective window in reversed order to the removal.
2. Press the key 2 so that this protective window is defined as "not OK." As it has to be calibrated (for the confirmation all LEDs light up).

The procedure of the protective window test is described in chapter „10.1.6 “Script “Self-test Protective Window”“ on page 86.

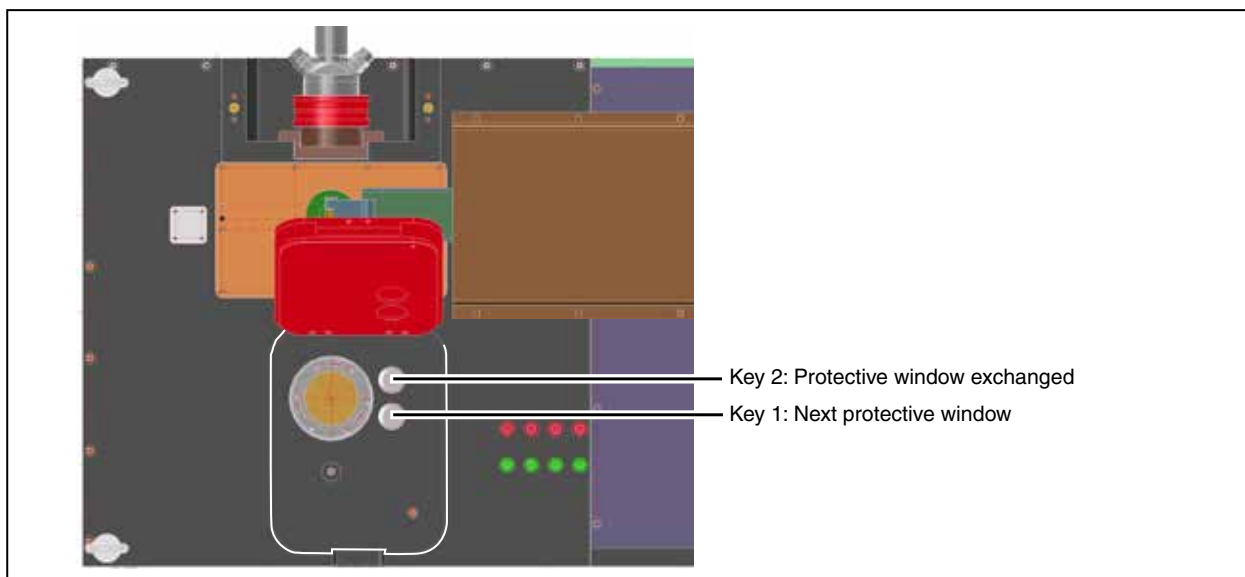

Fig.12.3: Function keys of the protective window exchanger

13 Storage/Transport

NOTICE

There is a danger of damage

A storage or transport with temperatures near or below the freezing point and with a cooling circuit which is not completely empty can lead to device damages.

- ▶ **Please empty the system of the cooling water completely.**

Please empty the cooling circuit completely by using compressed air. Connect the compressed air at the water inflow (Water In).

14 Dimensions housing

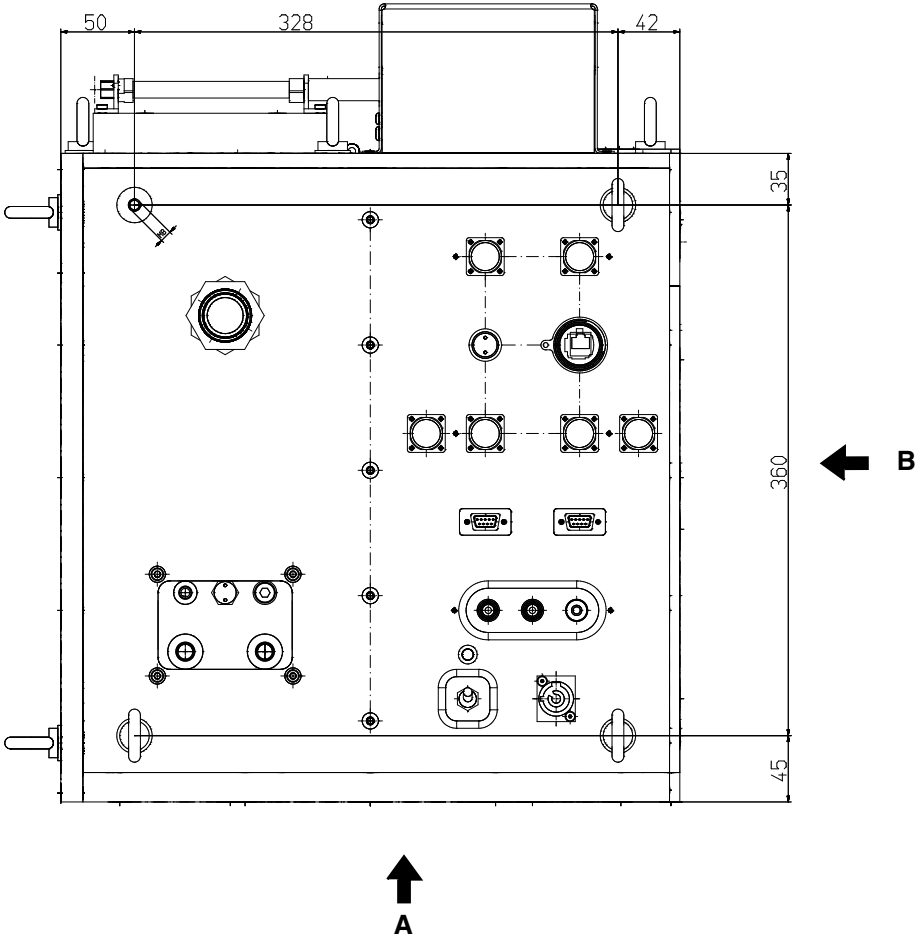

Dimensions (continuation)

View A

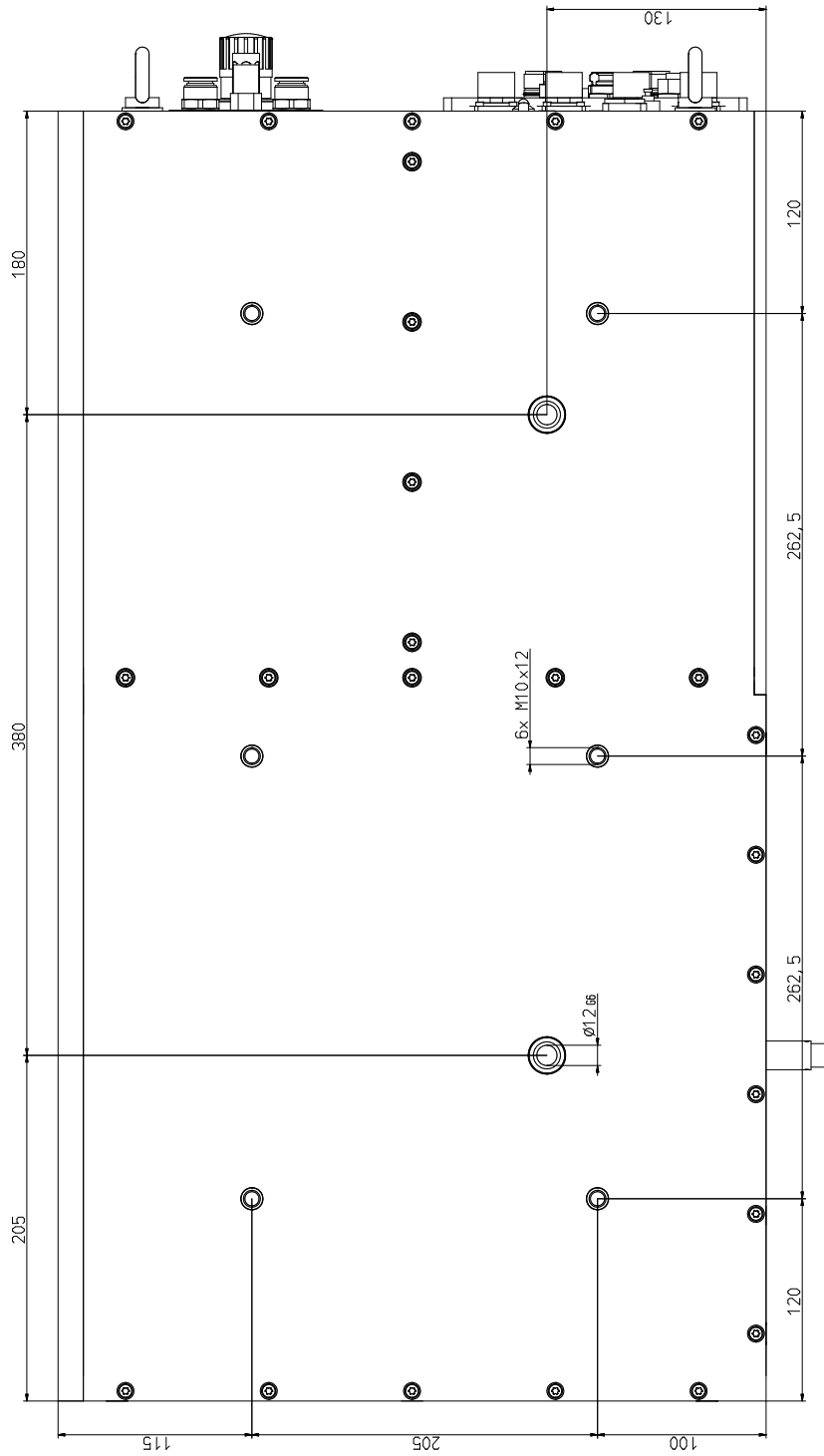

Dimensions (continuation)

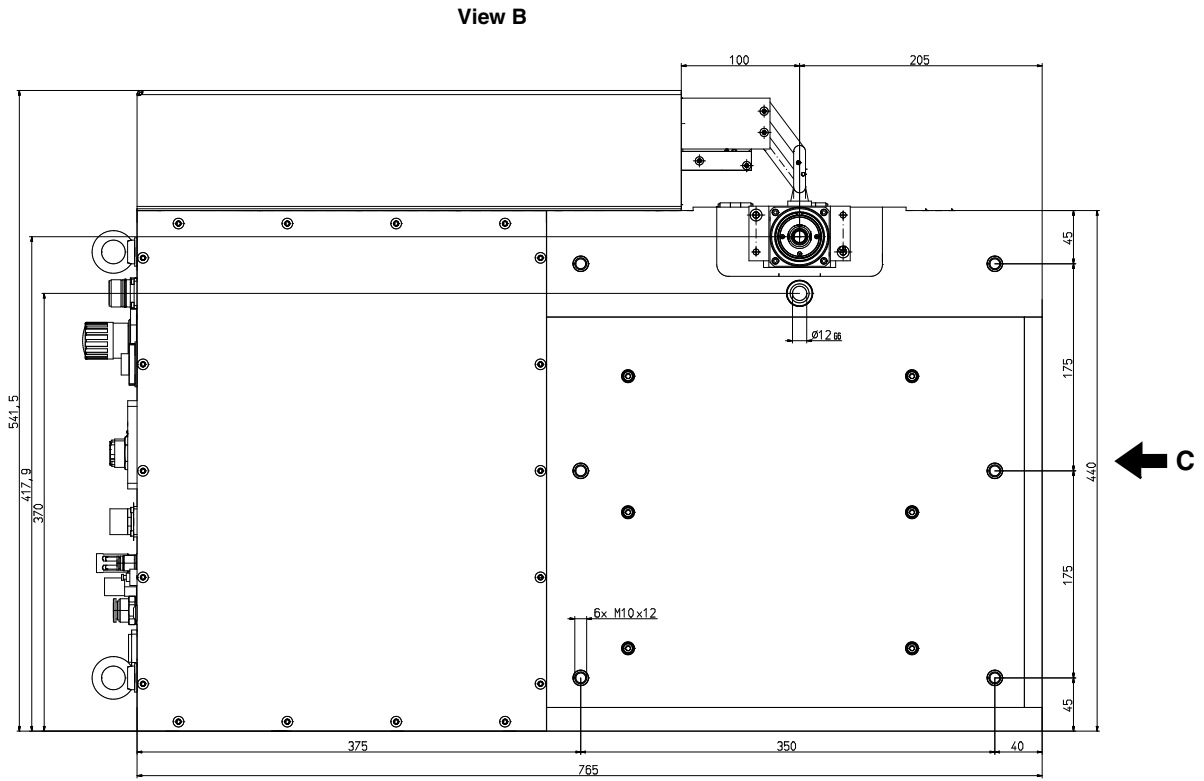

Dimensions (continuation)

View C

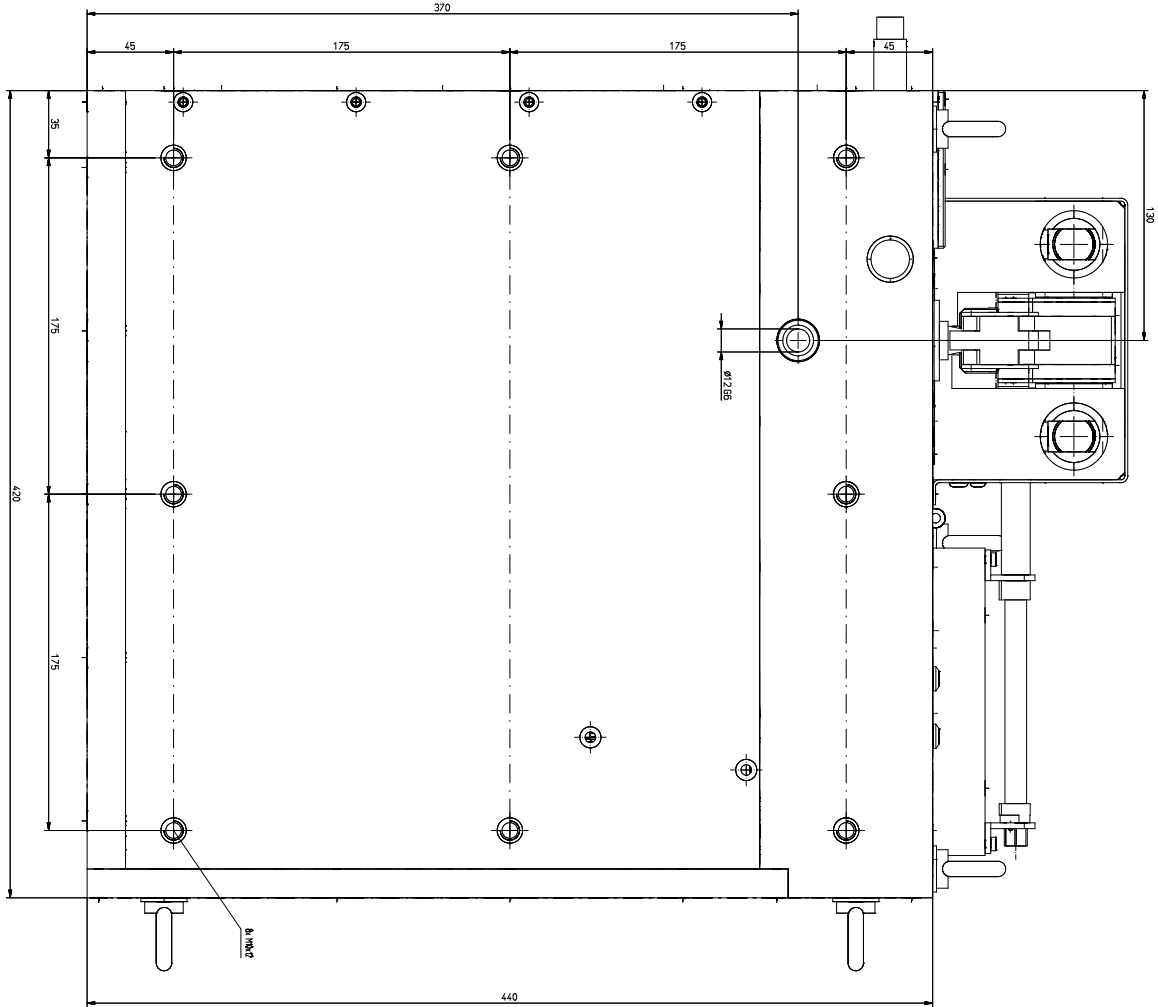

15 Center of mass

For the given measures a tolerance of approx. ± 20 mm is to be considered. When it comes to the determination of the center of mass (S) the focus measuring unit was located in the upper position (z-axis).

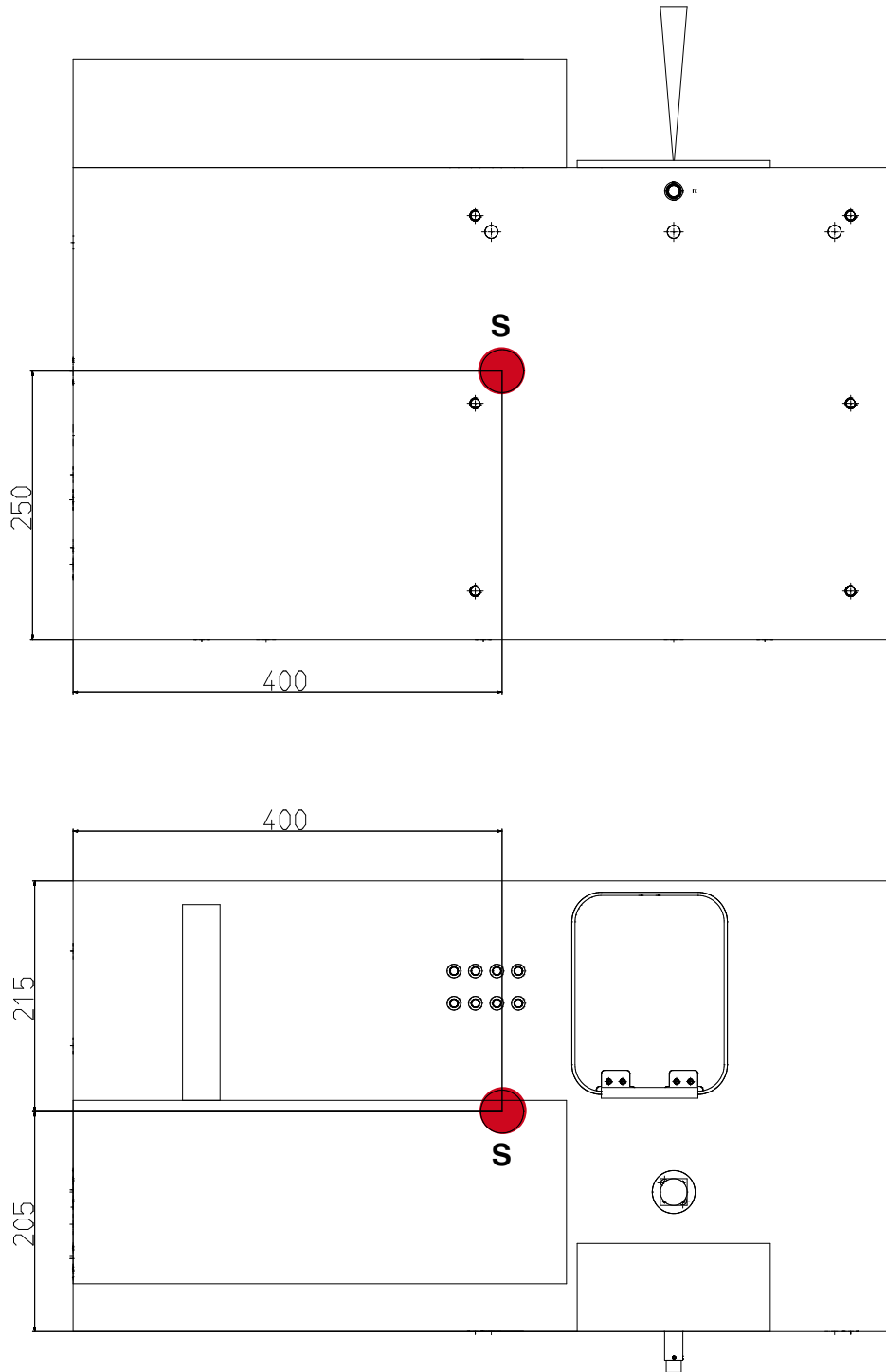

16 Technical data

Supply data		
Supply voltage	V	230 ± 10 %, 50 Hz
Maximum current consumption	A	20
Cooling water		
Flow rate	min. l/min	4
Water pressure	min. bar	2
	max. bar	8
Temperature stabilization with a control time constant < 5 min	°C	±1
Temperature gradient	°C/min	< 1
Conductance	µS	> 300
Compressed air, cleaned		
Minimum pressure	bar	4
Maximum pressure	bar	5

Power data		
Power measurement	W	500 ... 10.000
Temporal resolution power	s	10 (thermalization time 90)
Beam dimensions (depending on the Measurement optics)	µm	15 ... 3000
Divergence determination	mrad	50 ... 400
Rayleigh length	µm	30 ... 30,000
Temporal resolution beam measurement	s	from 2
Astigmatism	mm	up to 30
Loss angle	Degrees	0.1 ... 10

Other data		
Dimensions L x W x H	mm	750 x 400 x 550
Weight, approx.	kg	150

17 Accessories

Service kit with 8 protective windows, including interchangeable tools.....Order no. 801-015-005

18 Measures for the product disposal

According to the Electrical and Electronic Equipment Act (ElectroG) PRIMES is obliged to dispose PRIMES measuring devices manufactured after August 2005 free of charge. PRIMES is registered as a manufacturer with the EAR foundation (German register for electronic waste). Our registry number is the following: WEEE-Reg. – Nr. DE65549202.

You are welcome to return PRIMES measuring devices that are to be disposed free of charge to our address:

PRIMES GmbH
 Max-Planck-Str. 2
 D-64319 Pfungstadt
 Germany

